

INDUSTRIAL HOSES - compensators

In any pipeline exposed to temperature variations, vibrations, assembly stress, external impact and deformations, it is necessary to insert flexible parts such as hoses or expansion joints (compensators) in order to absorb movements of an installation. Bellow expansion joints can be installed in steam, water, gas, air, oil, chemicals, food and dry products pipelines.

Expansion joints are usually used to:

- accommodate thermal expansion of the pipeline,
- reduce stress in the pipeline,
- absorb vibrations and dampen noise,
- facilitate pipeline installation and assembly of couplings and valves.

Compensators are usually classified according to the kind of material the bellow (the basic part of all expansion joints with bellows) is made of:

- rubber expansion joints: the bellow is made of rubber reinforced with synthetic or steel cord (the kind of rubber depends on the working conditions of the compensator, medium, temperature, etc.), working temperature usually ranges up to +90°C (optionally up to +130°C),
- steel expansion joints: the bellow is made of AISI 321 acid resistant steel, steel compensators resistant to high temperature, corrosion and aggressive chemicals. Characterized by good mechanical characteristics and high fatigue strength.
- PTFE expansion joints: the bellow is made of annularly corrugated, thick-walled PTFE tube. They make a group of flexible joints with the highest grade of chemical resistance.
- fabric expansion joints made of fibreglass fabric optionally coated with silicone or PTFE layer. High chemical and temperature resistance. Designed to transfer exhaust fumes, gases, dust, and other fumes.

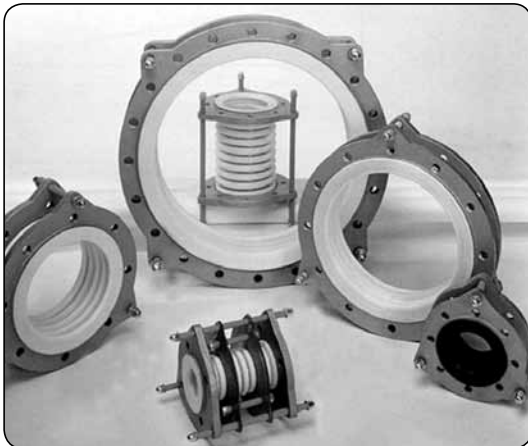
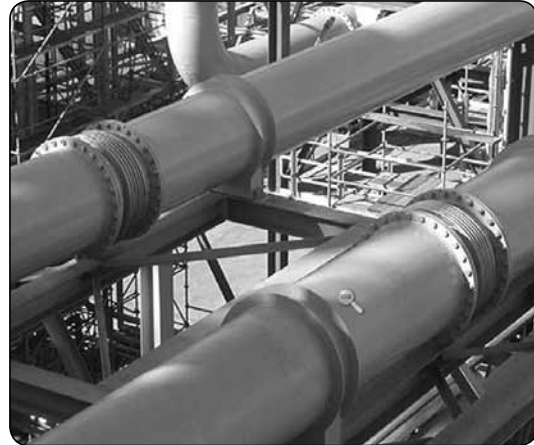
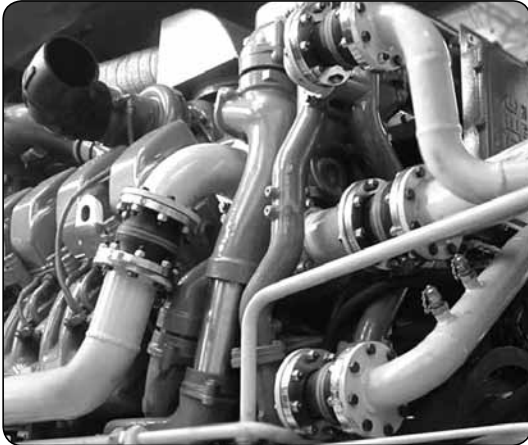

INDUSTRIAL HOSES - compensators

Rubber compensators

Working parameters of rubber expansion joints

The working parameters of rubber compensators given in the tables (working pressure, working temperature and displacement) are the maximum values and they must not occur simultaneously. The working pressure applies to the expansion joint working in the temperature of up to +50°C. At elevated temperatures, it is required to reduce the values given in the table regarding the maximum working pressure and displacement. The values of permissible vacuum pressure given in the tables apply to the compensators without vacuum supporting rings. A stainless steel ring can be fitted in the bellow of the rubber expansion joint if it is necessary. In that case the compensator can operate in the conditions of vacuum pressure or even close to full vacuum. Please contact Sales or Technical Department in the event of any doubts concerning permissible working parameters of the expansion joints in particular application.

compensator type	working temperature	displacement	bellow maximum working pressure [bar]		
			PN10	PN16	PN25
E-RE, E-CR, E-GR, E-YE, E-YL, E VITON, E-WH, E-BR	+50°C	100%	10	16	-
	+70°C	80%	8	12	-
	+100°C	60%	6	10	-
E-LPG	+50°C	100%	-	-	25
	+70°C	80%	-	-	20
	+100°C	60%	-	-	15
E-RP	+50°C	100%	10	-	-
	+70°C	80%	8	-	-
	+100°C	60%	6	-	-
E-RX	+70°C	100%	10	16	-
	+100°C	75%	7.5	12	-
	+130°C	50%	5	8	-
E-YS	+60°C	100%	10	16	-
	+100°C	60%	6	10	-
115 EPDM, 115NBR	+50°C	100%	10	16	-
	+70°C	80%	8	12	-
	+90°C	60%	6	10	-
T-EPDM, T-NBR, 1504	+40°C	100%	10	16	-
	+60°C	100%	6	10	-
	+80°C	80%	4	6.5	-
	+100°C	60%	2.5	4	-

Installation of rubber compensators

Rubber expansion joints are supplied as ready-to-use solutions. The compensators should not be covered and be accessible to regular maintenance. Rubber parts must not be covered with paint. During any welding work the bellow has to be covered up to protect it against high temperature and sparks. Permissible displacement, temperature, pressure and quality of rubber should be examined before installation. The pipes should be fixed to a base to eliminate any forces resulting from internal pipe pressure. To utilize the permissible displacement the distance between two pipe anchor points should be the same as the length of the compensator.

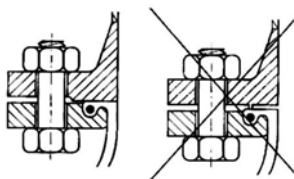

fig. 1

fig. 2

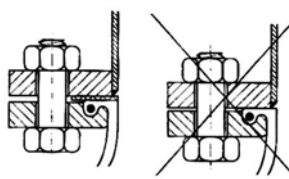

fig. 3

fig. 4

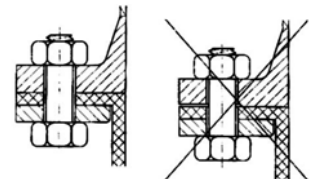

fig. 5

fig. 6

Rubber compensators

Joining screws should be fixed with their heads facing rubber bellow to allow displacements given in technical specifications. If it is not possible, threaded screws should not protrude more than $2 \div 3$ mm, to avoid damage of the bellow. Nuts should be tightened up one after another diagonally during mounting and again after installation start-up. If the screws and nuts are tightened up too hard, the seal can be crushed.

For safety reasons as well as to ensure the longest service life of an expansion joint, counter flanges have to be mounted properly (fig. 1 ÷ 6).

The seal of a counter flange has to be smooth and cover most of rubber surface (at least 60%) so as to provide right sealing (fig. 1). The compensators with full rubber flanges demand full and perfectly smooth counter flanges (fig. 5).

- fig. 1 - flange with smooth seal,
- fig. 2 - grooved and recess flanges must not be used, they damage rubber,
- fig. 3 - flange with plane seal in order to protect rubber surface,
- fig. 4 - sharp edges of the pipe can damage rubber surface,
- fig. 5 - full rubber flanges require full counter flanges to obtain proper sealing,
- fig. 6 - counter flange with a pad can both damage rubber surface and prevent tight contact.

Never cover rubber parts of a compensator with any paint or lubricant.

During any welding work the bellow has to be covered up to protect it against high temperature and spatter.

Before installation:

- remove dust and any foreign material that entered a compensator,
- a compensator should be secured against accidental or deliberate damage,
- any oil or lubricant must not fall on a compensator.

During start-up:

- check, if there is any leakage,
- if there is a need, check expansion limiters.

During service:

- a compensator must be easily accessible, not covered with any insulating material or paint,
- as soon as compensators start to work, it is essential to be sure its movements do not exceed permissible limits.

Maintenance:

- any kind of changes in the outer layer may indicate serious deformation,
- check screws tightening,
- check the range of compensator movements, that should be within permissible limits.

NOTE!

- the working parameters of compensators listed in the tables are the maximum values and must not occur simultaneously,
- working pressure applies to the compensator operating in the temperature of $+20^{\circ}\text{C}$,
- the values of permissible vacuum pressure given in the tables apply to the rubber compensators without vacuum supporting rings. A stainless steel ring can be fitted in the bellow of the rubber compensator if it is necessary. In that case the expansion joint can operate in the conditions of vacuum pressure or even close to full vacuum.
- the permissible displacement values given in the tables apply to the compensators operating in the temperature of up to $+50^{\circ}\text{C}$.

INDUSTRIAL HOSES - compensators

Rubber compensators



T - EPDM

Internal layer: EPDM rubber
Reinforcement: Nylon cord
External layer: EPDM rubber
Flanges: Galvanized carbon steel
Working temp.: Up to +100°C
 (depending on the medium)

Designed for installations transferring hot and cold water, cooling water with water treatment additives, drinking water, industrial water, chlorine solutions, glycols, acids, whitewash, esters, ketones, seawater. Not suitable for fluids with oil content. PZH (National Institute of Hygiene, Poland) certificate for contact with drinking water.

code	I.D. [mm]	DIN 2501 flange PN	length [mm]	axial movement [± mm]	lateral movement [mm]	angular movement [degrees]	working pressure [bar]
TG-T-EPDM-032	32	10/16	95	4/8	8	15	16
TG-T-EPDM-040	40	10/16	95	4/8	8	15	16
TG-T-EPDM-050	50	10/16	105	4/8	8	15	16
TG-T-EPDM-065	65	10/16	115	6/12	10	15	16
TG-T-EPDM-080	80	10/16	130	6/12	10	15	16
TG-T-EPDM-100	100	10/16	135	10/18	12	15	16
TG-T-EPDM-125	125	10/16	170	10/18	12	15	16
TG-T-EPDM-150	150	10/16	180	10/18	12	15	16
TG-T-EPDM-200	200	10	205	14/20	18	15	10
TG-T-EPDM-250	250	10	240	14/22	18	15	10
TG-T-EPDM-300	300	10	260	14/24	18	15	10
TG-T-EPDM-350	350	10	265	16/25	18	15	10
TG-T-EPDM-400	400	10	265	16/25	18	15	10
TG-T-EPDM-450	450	10	200	16/20	18	15	10
TG-T-EPDM-500	500	10	200	16/20	18	15	10
TG-T-EPDM-600	600	10	250	16/20	18	15	10



T - NBR

Internal layer: NBR rubber
Reinforcement: Nylon cord
External layer: NBR rubber
Flanges: Galvanized carbon steel
Working temp.: Up to +80°C
 (depending on the medium)

Designed for installations transferring mineral oils, vegetable or animal fats, aerosol oils, water with anti-corrosion additives.

code	I.D. [mm]	DIN 2501 flange PN	length [mm]	axial movement [± mm]	lateral movement [mm]	angular movement [degrees]	working pressure [bar]
TG-T-NBR-032	32	10/16	95	4/8	8	15	16
TG-T-NBR-040	40	10/16	95	4/8	8	15	16
TG-T-NBR-050	50	10/16	105	4/8	8	15	16
TG-T-NBR-065	65	10/16	115	6/12	10	15	16
TG-T-NBR-080	80	10/16	130	6/12	10	15	16
TG-T-NBR-100	100	10/16	135	10/18	12	15	16
TG-T-NBR-125	125	10/16	170	10/18	12	15	16
TG-T-NBR-150	150	10/16	180	10/18	12	15	16
TG-T-NBR-200	200	10	205	14/20	18	15	10

INDUSTRIAL HOSES - compensators



115 EPDM

Internal layer: EPDM rubber
Reinforcement: Nylon cord
External layer: EPDM rubber
Flanges: Galvanized carbon steel
Working temp.: From -30°C up to +90°C
 (depending on the medium)

Designed for installations transferring hot and cold water, water with water treatment additives, industrial water, seawater, glycols, weak acids, bases, esters and ketones. Not suitable for fluids with oil content. BV (Bureau Veritas) Certificate.

code	I.D. [mm]	DIN 2501 flange PN	length [mm]	axial movement [± mm]	lateral movement [mm]	angular movement [degrees]	working pressure [bar]	vacuum [bar]
TG-115E-032	32	10/16	130	12/20	14	15	16	0.88
TG-115E-040	40	10/16	130	12/20	14	15	16	0.88
TG-115E-050	50	10/16	130	12/20	14	15	16	0.88
TG-115E-065	65	10/16	130	12/20	14	15	16	0.88
TG-115E-080	80	10/16	130	12/20	14	15	16	0.88
TG-115E-100	100	10/16	130	12/20	14	15	16	0.88
TG-115E-125	125	10/16	130	12/20	14	15	16	0.88
TG-115E-150	150	10/16	130	12/20	14	15	16	0.88
TG-115E-200	200	10	130	12/25	14	15	10	0.88
TG-115E-250	250	10	130	16/25	22	15	10	0.88
TG-115E-300	300	10	130	16/25	22	15	10	0.88
TG-101E-350	350	10	200	16/25	22	15	10	0.88
TG-101E-400	400	10	200	16/25	22	15	10	0.88
TG-101E-450	450	10	200	16/25	22	15	10	0.88
TG-101E-500	500	10	200	16/25	22	15	10	0.88
TG-100E-600	600	10	265	16/25	22	15	10	0.88



115 NBR

Internal layer: NBR rubber
Reinforcement: Nylon cord
External layer: CR rubber
Flanges: Galvanized carbon steel
Working temp.: From -30°C up to +90°C
 (depending on the medium)

Designed for installations transferring mineral oils, vegetable or animal fats, aerosol oils, water with anti-corrosion additives.

code	I.D. [mm]	DIN 2501 flange PN	length [mm]	axial movement [± mm]	lateral movement [mm]	angular movement [degrees]	working pressure [bar]	vacuum [bar]
TG-115N-032	32	10/16	130	12/20	14	15	16	0.88
TG-115N-040	40	10/16	130	12/20	14	15	16	0.88
TG-115N-050	50	10/16	130	12/20	14	15	16	0.88
TG-115N-065	65	10/16	130	12/20	14	15	16	0.88
TG-115N-080	80	10/16	130	12/20	14	15	16	0.88
TG-115N-100	100	10/16	130	12/20	14	15	16	0.88
TG-115N-125	125	10/16	130	12/20	14	15	16	0.88
TG-115N-150	150	10/16	130	12/20	14	15	16	0.88
TG-115N-200	200	10	130	12/25	14	15	10	0.88
TG-115N-250	250	10	130	16/25	22	15	10	0.88
TG-115N-300	300	10	130	16/25	22	15	10	0.88

INDUSTRIAL HOSES - compensators

Rubber compensators



1504

Internal layer: EPDM rubber
Reinforcement: Nylon cord
External layer: EPDM rubber
Connections: BSP male thread, cast iron, zinc-plated
Working temp.: From -10°C up to +100°C
 (depending on the medium)

Designed to absorb vibration and linear or angular displacement in water installation. Not suitable for fluids with oil content. PZH (National Institute of Hygiene, Poland) certificate for contact with drinking water.

code	nominal diameter [mm]	thread size [inch]	length [mm]	compression [mm]	expansion [mm]	lateral movement [mm]	angular movement [degrees]	working pressure [bar]
TG-1504-E-15	15	1/2	200	22	6	22	45	10
TG-1504-E-20	20	3/4	200	22	6	22	45	10
TG-1504-E-25	25	1	200	22	6	22	45	10
TG-1504-E-32	32	1.1/4	200	22	6	22	45	10
TG-1504-E-38	38	1.1/2	200	22	6	22	45	10
TG-1504-E-50	50	2	200	22	6	22	45	10
TG-1504-E-65	65	2.1/2	220	22	6	22	45	10
TG-1504-E-75	75	3	220	22	6	22	45	10



E - RP

Internal layer: Butyl rubber (IIR) / EPDM
Reinforcement: Nylon cord
External layer: EPDM rubber
Flanges: Galvanized carbon steel
Working temp.: From -40°C up to +90°C
 (with peaks up to +120°C depending on the medium)

Intended for sanitary installations, cold or hot water, swimming pool water, seawater and drinking water. Not suitable for mineral oils, cooling water with oil-based anti-corrosion additives, oily air and any installation where the constant working pressure exceeds 10 bar. Marked with a single red dot on a bellow.

code	I.D. [mm]	DIN 2501 flange PN	length [mm]	axial movement [± mm]	lateral movement [± mm]	angular movement [± degrees]	working pressure [bar]	vacuum [bar]
TG-E-RP-025	25	10	130	20/30	30	30	10	0.3
TG-E-RP-032	32	10	130	20/30	30	30	10	0.3
TG-E-RP-040	40	10	130	20/30	30	30	10	0.3
TG-E-RP-050	50	10	130	20/30	30	30	10	0.3
TG-E-RP-065	65	10	130	20/30	30	30	10	0.3
TG-E-RP-080	80	10	130	20/30	30	30	10	0.2
TG-E-RP-100	100	10	130	20/30	30	20	10	0.2
TG-E-RP-125	125	10	130	20/30	30	20	10	0.2
TG-E-RP-150	150	10	130	20/30	30	20	10	0.1

INDUSTRIAL HOSES - compensators

Rubber compensators



E - CR

Internal layer: CR rubber
Reinforcement: Nylon cord
External layer: CR rubber
Flanges: Galvanized carbon steel
Working temp.: From -25°C up to +90°C
 (with peaks up to +100°C depending on the medium)

Designed for installations transferring hot and cold water (not drinking water), seawater, cooling water with water treatment additives, municipal sewage, oily water, compressed air (not hot). Not suitable for heating oil, diesel, petrol or other petrochemical products, acids and bases. Marked with CR letters on a bellow, no stripe.

code	I.D. [mm]	DIN 2501 flange PN	length [mm]	axial movement [± mm]	lateral movement [± mm]	angular movement [± degrees]	working pressure [bar]	vacuum [bar]
TG-E-CR-025	25	16	130	20/30	30	30	16	1
TG-E-CR-032	32	16	130	20/30	30	30	16	1
TG-E-CR-040	40	16	130	20/30	30	30	16	1
TG-E-CR-050	50	16	130	20/30	30	30	16	1
TG-E-CR-065	65	16	130	20/30	30	30	16	0.7
TG-E-CR-080	80	16	130	20/30	30	30	16	0.6
TG-E-CR-100	100	16	130	20/30	30	20	16	0.4
TG-E-CR-125	125	16	130	20/30	30	20	16	0.3
TG-E-CR-150	150	16	130	20/30	30	20	16	0.3
TG-E-CR-200	200	10	130	30/25	30	10	10	0.3
TG-E-CR-250	250	10	130	30/10	15	5	10	0.2
TG-E-CR-300	300	10	130	30/10	15	5	10	0.1



E - RE

Internal layer: Butyl rubber (IIR) / EPDM
Reinforcement: Nylon cord
External layer: EPDM rubber
Flanges: Galvanized carbon steel
Working temp.: From -40°C up to +100°C
 (with peaks up to +120°C depending on the medium)

Designed for installations transferring water, seawater, cooling water with water treatment additives, drinking water, low concentration acids and bases, solutions of salts, esters and ketones. Not suitable for mineral oils, cooling water with oil-based anti-corrosion additives, oily air. Marked with a single red stripe on a bellow.

code	I.D. [mm]	DIN 2501 flange PN	length [mm]	axial movement [± mm]	lateral movement [± mm]	angular movement [± degrees]	working pressure [bar]	vacuum [bar]
TG-E-RE-025	25	16	130	20/30	30	30	16	1
TG-E-RE-032	32	16	130	20/30	30	30	16	1
TG-E-RE-040	40	16	130	20/30	30	30	16	1
TG-E-RE-050	50	16	130	20/30	30	30	16	1
TG-E-RE-065	65	16	130	20/30	30	30	16	0.7
TG-E-RE-080	80	16	130	20/30	30	30	16	0.6
TG-E-RE-100	100	16	130	20/30	30	20	16	0.4
TG-E-RE-125	125	16	130	20/30	30	20	16	0.3
TG-E-RE-150	150	16	130	20/30	30	20	16	0.3
TG-E-RE-200	200	10	130	30/25	30	10	10	0.3
TG-E-RE-250	250	10	130	30/10	15	5	10	0.2
TG-E-RE-300	300	10	130	30/10	15	5	10	0.1

INDUSTRIAL HOSES - compensators

Rubber compensators



E - YE

Internal layer: NBR rubber
Reinforcement: Nylon cord
External layer: CR rubber
Flanges: Galvanized carbon steel
Working temp.: From -20°C up to +90°C
 (with peaks up to +100°C depending on the medium)

Designed for installations conveying petrochemical products with aromatic content up to 50%, oily air, natural gas (not LPG), oily water, cooling water with anti-corrosion additives. Marked with a single yellow stripe on a bellow.

code	I.D. [mm]	DIN 2501 flange PN	length [mm]	axial movement [± mm]	lateral movement [± mm]	angular movement [± degrees]	working pressure [bar]	vacuum [bar]
TG-E-YE-025	25	16	130	20/30	30	30	16	1
TG-E-YE-032	32	16	130	20/30	30	30	16	1
TG-E-YE-040	40	16	130	20/30	30	30	16	1
TG-E-YE-050	50	16	130	20/30	30	30	16	1
TG-E-YE-065	65	16	130	20/30	30	30	16	0.7
TG-E-YE-080	80	16	130	20/30	30	30	16	0.6
TG-E-YE-100	100	16	130	20/30	30	20	16	0.4
TG-E-YE-125	125	16	130	20/30	30	20	16	0.3
TG-E-YE-150	150	16	130	20/30	30	20	16	0.3
TG-E-YE-200	200	10	130	30/25	30	10	10	0.3
TG-E-YE-250	250	10	130	30/10	15	5	10	0.2
TG-E-YE-300	300	10	130	30/10	15	5	10	0.1



E - YL

Internal layer: NBR rubber
Reinforcement: Nylon cord
External layer: CR rubber
Flanges: Galvanized carbon steel
Working temp.: From -40°C up to +90°C
 (with peaks up to +100°C depending on the medium)

Designed for installations conveying petrochemical products, petrol, diesel, heating oil, JET A1 jet fuel, kerosene. Marked with a single yellow stripe and white LT letters on a bellow.

code	I.D. [mm]	DIN 2501 flange PN	length [mm]	axial movement [± mm]	lateral movement [± mm]	angular movement [± degrees]	working pressure [bar]	vacuum [bar]
TG-E-YL-025	25	16	130	20/30	30	30	16	1
TG-E-YL-032	32	16	130	20/30	30	30	16	1
TG-E-YL-040	40	16	130	20/30	30	30	16	1
TG-E-YL-050	50	16	130	20/30	30	30	16	1
TG-E-YL-065	65	16	130	20/30	30	30	16	0.7
TG-E-YL-080	80	16	130	20/30	30	30	16	0.6
TG-E-YL-100	100	16	130	20/30	30	20	16	0.4
TG-E-YL-125	125	16	130	20/30	30	20	16	0.3
TG-E-YL-150	150	16	130	20/30	30	20	16	0.3
TG-E-YL-200	200	10	130	30/25	30	10	10	0.3
TG-E-YL-250	250	10	130	30/10	15	5	10	0.2
TG-E-YL-300	300	10	130	30/10	15	5	10	0.1

INDUSTRIAL HOSES - compensators

Rubber compensators



E - GR

Internal layer: CSM rubber (Hypalon)
Reinforcement: Nylon cord
External layer: CSM rubber (Hypalon)
Flanges: Galvanized carbon steel
Working temp.: From -20°C up to +100°C
 (with peaks up to +110°C depending on the medium)

Intended for installations conveying chemical or petrochemical products with aromatic content up to 50%, acids, bases, oily air (up to +90°C), natural gas (not LPG), oily water, cooling water with anti-corrosion additives. Marked with a single green stripe on a bellow.

code	I.D. [mm]	DIN 2501 flange PN	length [mm]	axial movement [± mm]	lateral movement [± mm]	angular movement [± degrees]	working pressure [bar]	vacuum [bar]
TG-E-GR-025	25	16	130	20/30	30	30	16	1
TG-E-GR-032	32	16	130	20/30	30	30	16	1
TG-E-GR-040	40	16	130	20/30	30	30	16	1
TG-E-GR-050	50	16	130	20/30	30	30	16	1
TG-E-GR-065	65	16	130	20/30	30	30	16	0.7
TG-E-GR-080	80	16	130	20/30	30	30	16	0.6
TG-E-GR-100	100	16	130	20/30	30	20	16	0.4
TG-E-GR-125	125	16	130	20/30	30	20	16	0.3
TG-E-GR-150	150	16	130	20/30	30	20	16	0.3
TG-E-GR-200	200	10	130	30/25	30	10	10	0.3
TG-E-GR-250	250	10	130	30/10	15	5	10	0.2
TG-E-GR-300	300	10	130	30/10	15	5	10	0.1



E - WH

Internal layer: White NBR rubber
Reinforcement: Nylon cord
External layer: CR rubber
Flanges: Galvanized carbon steel
Working temp.: From -20°C up to +90°C
 (with peaks up to +100°C depending on the medium)

Intended for installations conveying food products, also oil and fat containing foods. Not suitable for drinking water. Marked with a single white stripe on a bellow.

code	I.D. [mm]	DIN 2501 flange PN	length [mm]	axial movement [± mm]	lateral movement [± mm]	angular movement [± degrees]	working pressure [bar]	vacuum [bar]
TG-E-WH-025	25	16	130	20/30	30	30	16	1
TG-E-WH-032	32	16	130	20/30	30	30	16	1
TG-E-WH-040	40	16	130	20/30	30	30	16	1
TG-E-WH-050	50	16	130	20/30	30	30	16	1
TG-E-WH-065	65	16	130	20/30	30	30	16	0.7
TG-E-WH-080	80	16	130	20/30	30	30	16	0.6
TG-E-WH-100	100	16	130	20/30	30	20	16	0.4
TG-E-WH-125	125	16	130	20/30	30	20	16	0.3
TG-E-WH-150	150	16	130	20/30	30	20	16	0.3
TG-E-WH-200	200	10	130	30/25	30	10	10	0.3
TG-E-WH-250	250	10	130	30/10	15	5	10	0.2
TG-E-WH-300	300	10	130	30/10	15	5	10	0.1

INDUSTRIAL HOSES - compensators

Rubber compensators



E - RX

Internal layer: EPDM rubber
Reinforcement: Polymer cord
External layer: EPDM rubber
Flanges: Galvanized carbon steel
Working temp.: From -40°C up to +130°C
 (with peaks up to +150°C depending on the medium)

Designed for installations conveying hot water, cooling water, hot air. Not suitable for mineral oils, cooling water with oil-based anti-corrosion additives, oily air. Marked with a double red stripe on a bellow.

code	I.D. [mm]	DIN 2501 flange PN	length [mm]	axial movement [± mm]	lateral movement [± mm]	angular movement [± degrees]	working pressure [bar]	vacuum [bar]
TG-E-RX-025	25	16	130	20/30	30	30	16	1
TG-E-RX-032	32	16	130	20/30	30	30	16	1
TG-E-RX-040	40	16	130	20/30	30	30	16	1
TG-E-RX-050	50	16	130	20/30	30	30	16	1
TG-E-RX-065	65	16	130	20/30	30	30	16	0.7
TG-E-RX-080	80	16	130	20/30	30	30	16	0.6
TG-E-RX-100	100	16	130	20/30	30	20	16	0.4
TG-E-RX-125	125	16	130	20/30	30	20	16	0.3
TG-E-RX-150	150	16	130	20/30	30	20	16	0.3
TG-E-RX-200	200	10	130	30/25	30	10	10	0.3
TG-E-RX-250	250	10	130	30/10	15	5	10	0.2
TG-E-RX-300	300	10	130	30/10	15	5	10	0.1



E - LPG

Internal layer: Conductive NBR rubber
Reinforcement: Nylon cord
External layer: Conductive CR rubber
Flanges: Galvanized carbon steel
Working temp.: From -20°C up to +90°C
 (with peaks up to +100°C depending on the medium)

Designed for application in tankers, fuel installations and petrol stations to transfer LPG (Liquid Petroleum Gas) according to EN 589. Germanischer Lloyd Certificate. Available with ASA 300 flanges. Marked with a single orange stripe on a bellow.

code	I.D. [mm]	DIN 2635 flange PN	length [mm]	axial movement [± mm]	lateral movement [± mm]	angular movement [± degrees]	working pressure [bar]	vacuum [bar]
TG-E-OR-025	25	40	130	30	30	30	25	1
TG-E-OR-032	32	40	130	30	30	30	25	1
TG-E-OR-040	40	40	130	30	30	30	25	1
TG-E-OR-050	50	40	130	30	30	30	25	1
TG-E-OR-065	65	40	130	30	30	30	25	1
TG-E-OR-080	80	40	130	30	30	30	25	1
TG-E-OR-100	100	40	130	30	30	30	25	1

INDUSTRIAL HOSES - compensators

Rubber compensators



E - VITON

Internal layer: FPM (Viton)
Reinforcement: Rubber-coated Nylon cord
External layer: Conductive ECO rubber
Flanges: Galvanized carbon steel
Working temp.: From -15°C up to +90°C
 (with peaks up to +130°C depending on the medium)

Designed for chemical and petrochemical installations, sulphur removal, application in power plants, etc. Extremely resistant to the influence of hot oils, benzene, xylene, products with aromatic content up to 50%, biodiesel and other aggressive media. Marked with a white-green-white stripe on a bellows.

code	I.D. [mm]	DIN 2501 flange PN	length [mm]	axial movement [± mm]	lateral movement [± mm]	angular movement [± degrees]	working pressure [bar]	vacuum [bar]
TG-E-VI-025	25*	16	130	20/30	30	30	16	1
TG-E-VI-032	32	16	130	20/30	30	30	16	1
TG-E-VI-040	40	16	130	20/30	30	30	16	1
TG-E-VI-050	50	16	130	20/30	30	30	16	1
TG-E-VI-065	65	16	130	20/30	30	30	16	0.7
TG-E-VI-080	80	16	130	20/30	30	30	16	0.6
TG-E-VI-100	100	16	130	20/30	30	20	16	0.4
TG-E-VI-125	125	16	130	20/30	30	20	16	0.3
TG-E-VI-150	150	16	130	20/30	30	20	16	0.3
TG-E-VI-200	200	10	130	30/25	30	10	10	0.3



E - YS

Internal layer: HNBR rubber
Reinforcement: Steel cord
External layer: CR rubber
Flanges: Galvanized carbon steel
Working temp.: From -35°C up to +100°C
 (with peaks up to +120°C depending on the medium)

Intended for installations conveying chemical or petrochemical products with aromatic content up to 50%, cooling water with oil-based anti-corrosion additives, lubricating and hydraulic oil, seawater. Marked with a yellow-blue-yellow stripe on a bellows.

code	I.D. [mm]	DIN 2501 flange PN	length [mm]	axial movement [± mm]	lateral movement [± mm]	angular movement [± degrees]	working pressure [bar]	vacuum [bar]
TG-E-YS-025	25	16	130	15/30	15	20	16	1
TG-E-YS-032	32	16	130	15/30	15	20	16	1
TG-E-YS-040	40	16	130	15/30	15	20	16	1
TG-E-YS-050	50	16	130	15/30	15	20	16	1
TG-E-YS-065	65	16	130	15/30	15	20	16	1
TG-E-YS-080	80	16	130	15/30	15	20	16	1
TG-E-YS-100	100	16	130	15/30	15	15	16	0.8
TG-E-YS-125	125	16	130	15/30	15	15	16	0.7
TG-E-YS-150	150	16	130	15/30	15	15	16	0.7
TG-E-YS-200	200	10	130	20/15	10	5	10	0.7
TG-E-YS-250	250	10	130	20/15	10	5	10	0.7
TG-E-YS-300	300	10	130	20/15	10	5	10	0.6

INDUSTRIAL HOSES - compensators

Rubber compensators



E - BR

Internal layer: BR/NR rubber
Reinforcement: Polyester cord
External layer: BR/NR rubber
Flanges: Galvanized carbon steel
Working temp.: From -50°C up to +70°C
 (with peaks up to +90°C depending on the medium)

Due to superior abrasion resistance compensators are suitable for the transfer of such media as: suspensions, sediment, emulsion, water with all kinds of additives, with solid particles, with abrasive effect. They are not designed to transfer media containing oils, fats or petrochemical products. Marked with a single blue dot on a bellows.

code	I.D. [mm]	DIN 2501 flange PN	length [mm]	axial movement [± mm]	lateral movement [± mm]	angular movement [± degrees]	working pressure [bar]	vacuum [bar]
TG-E-BR-025	25	16	130	20/30	30	25	16	1
TG-E-BR-032	32	16	130	20/30	30	25	16	1
TG-E-BR-040	40	16	130	20/30	30	25	16	1
TG-E-BR-050	50	16	130	20/30	30	25	16	1
TG-E-BR-065	65	16	130	20/30	30	25	16	0.7
TG-E-BR-080	80	16	130	20/30	30	25	16	0.6
TG-E-BR-100	100	16	130	20/30	30	15	16	0.4
TG-E-BR-125	125	16	130	20/30	30	15	16	0.3
TG-E-BR-150	150	16	130	20/30	30	15	16	0.3
TG-E-BR-200	200	10	130	30/25	30	5	10	0.3
TG-E-BR-250	250	10	130	30/10	15	5	10	0.2
TG-E-BR-300	300	10	130	30/10	15	5	10	0.1

INDUSTRIAL HOSES - compensators

Rubber compensators - accessories for E type

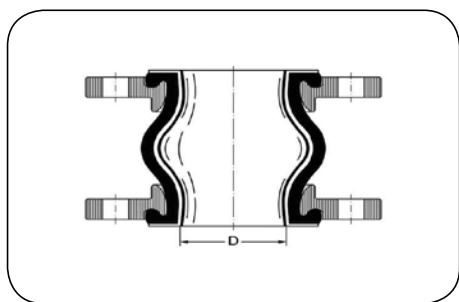

Internal PTFE liner

PTFE liner is applied when chemical resistance of rubber bellows is not sufficient for the medium. Suitable for almost all media. Available for compensators in the range of DN25 ÷ DN300 in diameter. Supplied integrated with a rubber compensator (factory-mounted). If the liner is used, displacement values given in the catalogue must be reduced by about 50%. Suitable for working pressure up to 6 bar. Not suitable for vacuum.

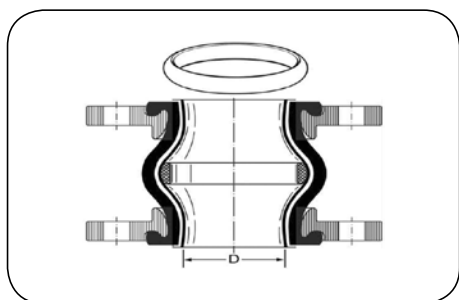

Internal PTFE liner + PTFE vacuum ring

Parameters are the same as for PTFE liner (see above) although with an additional PTFE ring it can be used for vacuum but only in the temperature up to +70°C.

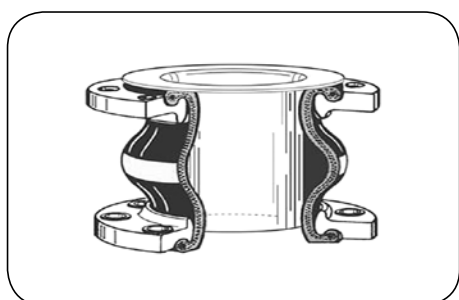

Internal flow liner

Made of 1.4571(AISI 316Ti) steel as a standard, applied when abrasive media may mechanically damage a rubber bellow (e.g. granules). Available for compensators in the range of DN 25÷DN600 in diameter. It can be from 1 to 3 mm thick depending on a diameter. The flow liner significantly reduces angular and lateral movement of the compensator.

Note: When the flow liner is used, the working diameter of the compensator is reduced. It is crucial to put a gasket between the flow liner and counter flange of a pipeline.

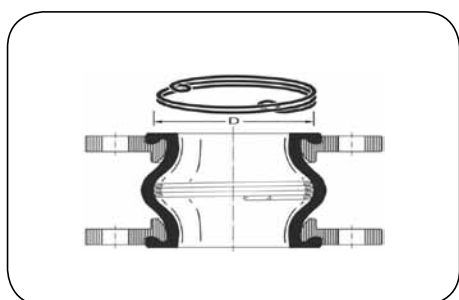

Internal supporting steel spiral

Applied when the value of working vacuum in a pipeline is higher than the vacuum of a particular compensator. Available for compensators in the range of DN50 ÷ DN300 in diameter. Made of 1.4571(AISI 316Ti) steel. The number and thickness of convolutions depend on the nominal diameter of the compensator. If the spiral is used, displacement values given in the catalogue must be reduced by about 50%.

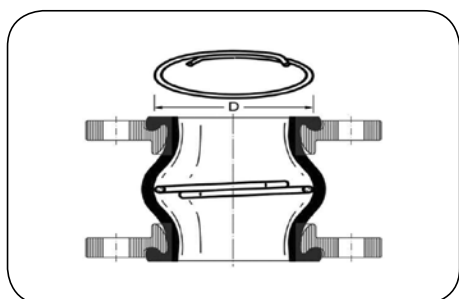

Internal supporting steel ring

Applied when the value of working vacuum in a pipeline is higher than the vacuum of a particular compensator. Available for compensators in the range of DN125 ÷ DN600 in diameter. Made of 1.4571(AISI 316Ti) steel. If the ring is used, displacement values given in the catalogue must be reduced by about 50%.

INDUSTRIAL HOSES - compensators

Rubber compensators - accessories for E type

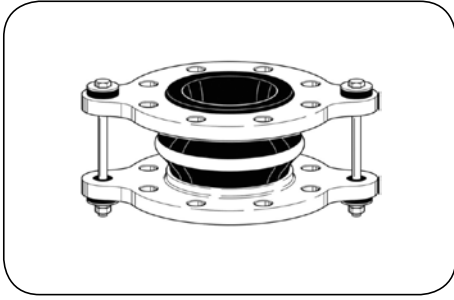

Tie rods

Tie rods are recommended when no sufficiently solid fix points can be built into an installation in order to transmit the reactive force from this installation. The force comes from the internal pressure. Available as a set integrated with the flanges of a compensator. For diameters up to DN300 they include rubber washers that additionally dampen noise and vibration.

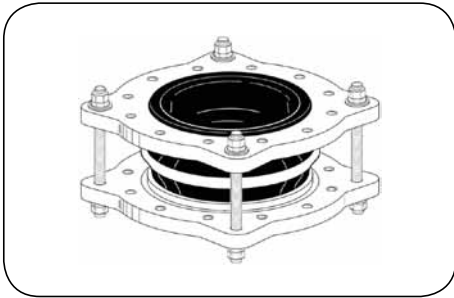

For diameters above DN350 tie rods include steel washers (spherical and conical).

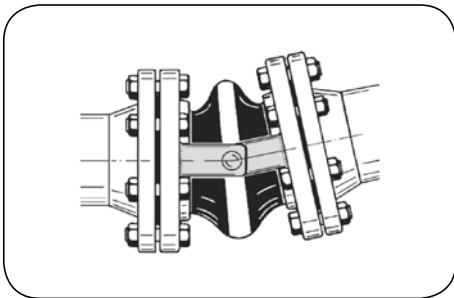

Custom made (only for angular displacement).

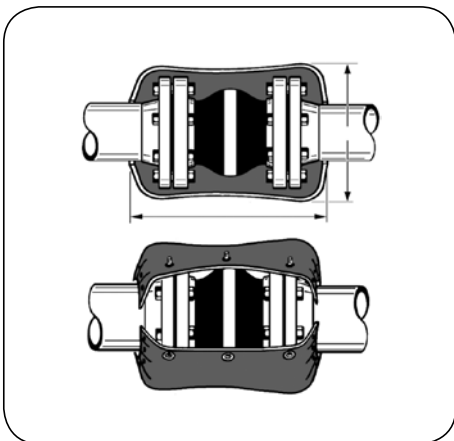

Fire-retardant protective cover

Made of several layers of fibreglass fabric with external silicone-aluminum-fibreglass layer. Designed for overall protection of a rubber compensator against direct impact of a very high temperature or even flame in the temperature up to +800°C for up to 30 minutes. The cover is also resistant to oil, chemicals and weather conditions. It is big enough to protect counter flanges of the installation as well. It has no impact on the permissible displacement of the compensator.

INDUSTRIAL HOSES - compensators

Steel compensators

Steel compensators are designed to absorb a particular amount of displacement of the pipeline according to specified working conditions and size. In order to obtain the maximum service life in the conditions of working pressure follow the recommendations listed below:

Before installation

Check if the compensator delivered to the installation spot has not been damaged during shipment. Any damage caused to the steel bellow may severely shorten service life of the compensator. Only if the assembly of installation is completed, the compensator can be fitted into position. It applies to pipe supports or moving props of the piping system in particular.

The compensator must not be used as a pipeline support neither carry its load. No torsion or rotation - an outcome of stress occurring in the pipeline during installation or service must be imposed on the compensator.

During installation

No mechanical impact e.g. heavy blow should be imposed on a compensator. It is unacceptable to drop the compensator on hard surface. Do not use rope or chain directly on the bellow to lift the compensator during installation. The compensators with internal sleeves should be installed pointing the flow direction. It is essential to maintain the alignment of the compensator with the pipeline during installation.

Nuts of compensators with flanges should be tightened up one after another diagonally in several attempts. The space left for the compensator in the pipeline must be exactly the same as the length required to install the compensator.

After installation

Remove all shipping bars and other devices employed to keep the initial stress of the compensator (if there were any). Check if the compensator has not been damaged during shipment. No foreign material can be trapped between the corrugations of the bellow. Check if all pipe guides and supports are adequate before pressure test of the installation. Never exceed the maximum working pressure. If the pipeline is covered with insulating coating, do not allow the material of the coating to enter the corrugation of the bellow.

During service

Working pressure and displacement of the compensator shall never exceed the permissible values. It is crucial to avoid pressure jumps caused either by faulty equipment or its malfunction. If the working conditions of installations such as pressure or temperature change it is recommended to re-examine the adequacy of the compensator for these modified working conditions.

Maintenance

Steel compensators are virtually maintenance-free. They only require periodic visual inspection during service. In case of any malfunction - leakage, cracks, signs of corrosion or damage of steel bellows in particular, the compensator must be replaced with a new one. Steel compensators are unrecoverable.

Temperature correction factor for steel compensators

The working parameters of steel compensators given in the tables are for the maximum working pressure of each particular type: 2.5 - 10 - 16 bar and for the temperature of +120°C.

In order to calculate the maximum working pressure for working temperature other than the one specified in the parameters, use the correction factors given in the table below.

working temperature [°C]	20	50	100	120	150	200	250	300	350	400	450	500	550
correction factor	1.183	1.095	1.026	1.000	0.962	0.912	0.863	0.823	0.794	0.769	0.750	0.735	0.725

INDUSTRIAL HOSES - compensators

Steel compensators



AX1T - PN 16

AX1SU-16: Welding ends
AX1FU-16: EN 1092-1 fixed flanges
AX1BU-16: EN 1092-1 swivel flanges
Material: AISI 321
Flanges: Carbon steel
Welding ends: Carbon steel
Working temp.: Up to +550°C
Working press.: Up to 16 bar
 (apply the temperature correction factor for temperatures above +120°C)

Axial compensators designed for application in pipelines to compensate axial and lateral movements. Stainless steel ends and compensators longer than standard are available on request.

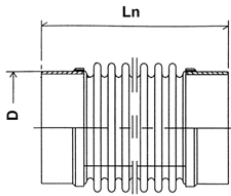

AX1SU-16 type

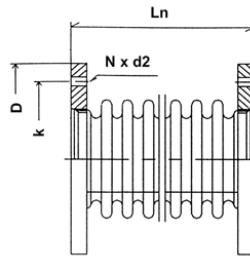

AX1FU-16 type

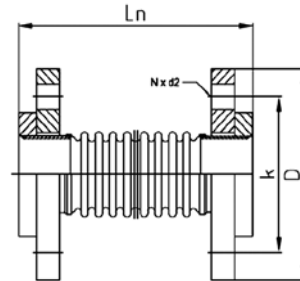

AX1BU-16 type

code	nominal diameter [mm]	angular movement [± mm]	elasticity [N/mm]		Ln	D	k	N x d2
			axial	lateral				
BMT-AX1SU-16-0040-16	DN 40	8	132.1	107.3	180	48.3	-	-
BMT-AX1SU-16-0050-22	DN 50	11	88.1	84.3	190	60.3	-	-
BMT-AX1SU-16-0065-24	DN 65	12	99.9	154.8	190	76.1	-	-
BMT-AX1SU-16-0080-22	DN 80	11	188.6	313.6	200	88.9	-	-
BMT-AX1SU-16-0100-30	DN 100	15	134.5	374	205	114.3	-	-
BMT-AX1SU-16-0125-38	DN 125	19	174.5	888.4	195	139.7	-	-
BMT-AX1SU-16-0150-38	DN 150	19	293.9	1163.6	230	168.3	-	-
BMT-AX1SU-16-0200-56	DN 200	28	249.2	1199.5	255	219.1	-	-
BMT-AX1SU-16-0250-56	DN 250	28	298.2	2186.6	255	273	-	-
BMT-AX1SU-16-0300-58	DN 300	29	398.2	3751.7	255	323.9	-	-
BMT-AX1FU-16-0040-16	DN 40	8	132.1	107.3	110	150	110	4 x 18
BMT-AX1FU-16-0050-22	DN 50	11	88.1	84.3	120	165	125	4 x 18
BMT-AX1FU-16-0065-24	DN 65	12	99.9	154.8	120	185	145	8 x 18
BMT-AX1FU-16-0080-22	DN 80	11	188.6	313.6	140	200	160	8 x 18
BMT-AX1FU-16-0100-30	DN 100	15	134.5	374	145	220	180	8 x 18
BMT-AX1FU-16-0125-38	DN 125	19	174.5	888.4	135	250	188	8 x 18
BMT-AX1FU-16-0150-38	DN 150	19	293.9	1163.6	170	285	212	8 x 22
BMT-AX1FU-16-0200-56	DN 200	28	249.2	1199.5	190	340	268	12 x 22
BMT-AX1FU-16-0250-56	DN 250	28	298.2	2186.6	200	405	355	12 x 26
BMT-AX1FU-16-0300-58	DN 300	29	398.2	3751.7	205	460	410	12 x 26
BMT-AX1BU-16-0040-16	DN 40	8	132.1	107.3	180	150	110	4 x 18
BMT-AX1BU-16-0050-22	DN 50	11	88.1	84.3	190	165	125	4 x 18
BMT-AX1BU-16-0065-24	DN 65	12	99.9	154.8	190	185	145	8 x 18
BMT-AX1BU-16-0080-22	DN 80	11	188.6	313.6	200	200	160	8 x 18
BMT-AX1BU-16-0100-30	DN 100	15	134.5	374	210	220	180	8 x 18
BMT-AX1BU-16-0125-38	DN 125	19	174.5	888.4	200	250	188	8 x 18
BMT-AX1BU-16-0150-38	DN 150	19	293.9	1163.6	245	285	212	8 x 22
BMT-AX1BU-16-0200-56	DN 200	28	249.2	1199.5	290	340	268	12 x 22
BMT-AX1BU-16-0250-56	DN 250	28	298.2	2186.6	300	405	355	12 x 26
BMT-AX1BU-16-0300-58	DN 300	29	398.2	3751.7	310	460	410	12 x 26

INDUSTRIAL HOSES - compensators

Steel compensators



UN1 - PN 2.5

UN1SU-03: Welding ends
UN1FU-03: Fixed flanges according to DIN 86044
UN1BU-03: Swivel flanges according to DIN 86044
Material: AISI 321
Flanges: Carbon steel
Welding ends: Carbon steel
Working temp.: Up to +550°C
Working press.: Up to 2.5 bar
 (apply the temperature correction factor for temperatures above +120°C)

General purpose compensators designed for application in pipelines to compensate axial and lateral movements.

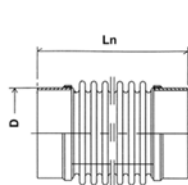

UN1SU-03 type

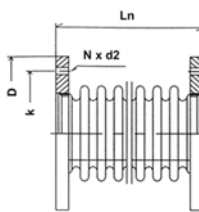

UN1FU-03 type

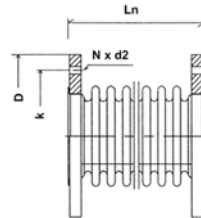

UN1BU-03 type

code	nominal diameter [mm]	movement [± mm]		elasticity [N/mm]		Ln	D	k	N x d2
		axial	lateral	axial	lateral				
BM-UN1SU-03-0040-015-0	DN 40	15	9	69	27	175	48.3	-	-
BM-UN1SU-03-0050-016-0	DN 50	16	8	77	46	175	60.3	-	-
BM-UN1SU-03-0065-016-0	DN 65	16	5	81	127	155	76.1	-	-
BM-UN1SU-03-0080-019-0	DN 80	19	6	76	76	170	88.9	-	-
BM-UN1SU-03-0100-018-0	DN 100	18	3	73	330	145	114.3	-	-
BM-UN1SU-03-0125-016-0	DN 125	16	2.5	148	966	150	139.7	-	-
BM-UN1SU-03-0150-023-0	DN 150	23	4	127	624	195	168.3	-	-
BM-UN1SU-03-0175-022-0	DN 175	22	3.5	139	907	195	193.7	-	-
BM-UN1SU-03-0200-025-0	DN 200	25	3.5	128	1054	195	219.1	-	-
BM-UN1SU-03-0250-024-0	DN 250	24	2.7	155	1970	195	273	-	-
BM-UN1SU-03-0300-025-0	DN 300	25	2.5	155	2793	235	323.9	-	-
BM-UN1FU-03-0040-015-0	DN 40	15	9	69	27	125	150	110	4 x 18
BM-UN1FU-03-0050-016-0	DN 50	16	8	77	46	130	165	125	4 x 18
BM-UN1FU-03-0065-016-0	DN 65	16	5	81	127	110	185	145	4 x 18
BM-UN1FU-03-0080-019-0	DN 80	19	6	76	76	130	200	160	8 x 18
BM-UN1FU-03-0100-018-0	DN 100	18	3	73	330	105	220	180	8 x 18
BM-UN1FU-03-0125-016-0	DN 125	16	2.5	148	966	115	250	210	8 x 18
BM-UN1FU-03-0150-023-0	DN 150	23	4	127	624	140	285	240	8 x 22
BM-UN1FU-03-0175-022-0	DN 175	22	3.5	139	907	145	315	270	8 x 22
BM-UN1FU-03-0200-025-0	DN 200	25	3.5	128	1054	125	320	280	8 x 18
BM-UN1FU-03-0250-024-0	DN 250	24	2.7	155	1970	125	375	335	12 x 18
BM-UN1FU-03-0300-025-0	DN 300	25	2.5	155	2793	125	440	395	12 x 22
BM-UN1BU-03-0040-015-0	DN 40	15	9	69	27	125	150	110	4 x 18
BM-UN1BU-03-0050-016-0	DN 50	16	8	77	46	130	165	125	4 x 18
BM-UN1BU-03-0065-016-0	DN 65	16	5	81	127	110	185	145	4 x 18
BM-UN1BU-03-0080-019-0	DN 80	19	6	76	76	130	200	160	8 x 18
BM-UN1BU-03-0100-018-0	DN 100	18	3	73	330	105	220	180	8 x 18
BM-UN1BU-03-0125-016-0	DN 125	16	2.5	148	966	115	250	210	8 x 18
BM-UN1BU-03-0150-023-0	DN 150	23	4	127	624	140	285	240	8 x 22
BM-UN1BU-03-0175-022-0	DN 175	22	3.5	139	907	145	315	270	8 x 22
BM-UN1BU-03-0200-025-0	DN 200	25	3.5	128	1054	125	320	280	8 x 18
BM-UN1BU-03-0250-024-0	DN 250	24	2.7	155	1970	125	375	335	12 x 18
BM-UN1BU-03-0300-025-0	DN 300	25	2.5	155	2793	125	440	395	12 x 22

INDUSTRIAL HOSES - compensators

Steel compensators



US1 - PN 2.5

US1SU-03: Welding ends
US1FU-03: Fixed flanges according to DIN 86044
US1BU-03: Swivel flanges according to DIN 86044
Material: AISI 321
Flanges: Carbon steel
Welding ends: Carbon steel
Working temp.: Up to +550°C
Working press.: Up to 2.5 bar
 (apply the temperature correction factor for temperatures above +120°C)

Compensators designed for application in exhaust fumes systems to compensate axial and lateral movements.

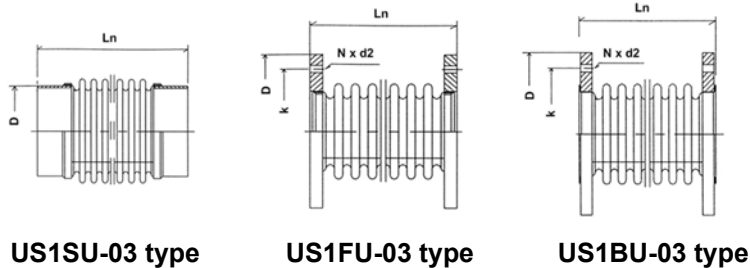

US1SU-03 type

US1FU-03 type

US1BU-03 type

code	nominal diameter [mm]	movement [± mm]		elasticity [N/mm]		Ln	D	k	N x d2
		axial	lateral	axial	lateral				
BM-US1SU-03-0040-015-0	DN40	15	9	69	27	175	48.3	-	-
BM-US1SU-03-0050-016-0	DN50	16	8	77	46	175	60.3	-	-
BM-US1SU-03-0065-016-0	DN65	16	5	81	127	155	76.1	-	-
BM-US1SU-03-0080-019-0	DN80	19	6	76	76	170	88.9	-	-
BM-US1SU-03-0100-018-0	DN100	18	3	73	330	145	114.3	-	-
BM-US1SU-03-0125-016-0	DN125	16	2.5	148	966	150	139.7	-	-
BM-US1SU-03-0150-023-0	DN150	23	4	127	624	195	168.3	-	-
BM-US1SU-03-0175-022-0	DN175	22	3.5	139	907	195	193.7	-	-
BM-US1SU-03-0200-025-0	DN200	25	3.5	128	1054	195	219.1	-	-
BM-US1SU-03-0250-024-0	DN250	24	2.7	155	1970	195	273	-	-
BM-US1SU-03-0300-025-0	DN300	25	2.5	155	2793	235	323.9	-	-
BM-US1FU-03-0040-015-0	DN40	15	9	69	27	125	150	110	4 x 18
BM-US1FU-03-0050-016-0	DN50	16	8	77	46	130	165	125	4 x 18
BM-US1FU-03-0065-016-0	DN65	16	5	81	127	110	185	145	4 x 18
BM-US1FU-03-0080-019-0	DN80	19	6	76	76	130	200	160	8 x 18
BM-US1FU-03-0100-018-0	DN100	18	3	73	330	105	220	180	8 x 18
BM-US1FU-03-0125-016-0	DN125	16	2.5	148	966	115	250	210	8 x 18
BM-US1FU-03-0150-023-0	DN150	23	4	127	624	140	285	240	8 x 22
BM-US1FU-03-0175-022-0	DN175	22	3.5	139	907	145	315	270	8 x 22
BM-US1FU-03-0200-025-0	DN200	25	3.5	128	1054	125	320	280	8 x 18
BM-US1FU-03-0250-024-0	DN250	24	2.7	155	1970	125	375	335	12 x 18
BM-US1FU-03-0300-025-0	DN300	25	2.5	155	2793	125	440	395	12 x 22
BM-US1BU-03-0040-015-0	DN40	15	9	69	27	125	150	110	4 x 18
BM-US1BU-03-0050-016-0	DN50	16	8	77	46	130	165	125	4 x 18
BM-US1BU-03-0065-016-0	DN65	16	5	81	127	110	185	145	4 x 18
BM-US1BU-03-0080-019-0	DN80	19	6	76	76	130	200	160	8 x 18
BM-US1BU-03-0100-018-0	DN100	18	3	73	330	105	220	180	8 x 18
BM-US1BU-03-0125-016-0	DN125	16	2.5	148	966	115	250	210	8 x 18
BM-US1BU-03-0150-023-0	DN150	23	4	127	624	140	285	240	8 x 22
BM-US1BU-03-0175-022-0	DN175	22	3.5	139	907	145	315	270	8 x 22
BM-US1BU-03-0200-025-0	DN200	25	3.5	128	1054	125	320	280	8 x 18
BM-US1BU-03-0250-024-0	DN250	24	2.7	155	1970	125	375	335	12 x 18
BM-US1BU-03-0300-025-0	DN300	25	2.5	155	2793	125	440	395	12 x 22

INDUSTRIAL HOSES - compensators

Steel compensators



US2 - PN 2.5

US2SU-03: Welding ends
US2FU-03: Fixed flanges according to DIN 86044
US2BU-03: Swivel flanges according to DIN 86044
Material: AISI 321
Flanges: Carbon steel
Welding ends: Carbon steel
Working temp.: Up to +550°C
Working press.: Up to 2.5 bar
 (apply the temperature correction factor for temperatures above +120°C)

Compensators designed for application in exhaust fumes systems to compensate axial and lateral movements.

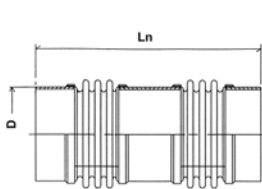

US2SU-03 type

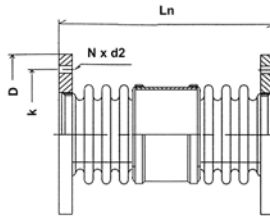

US2FU-03 type

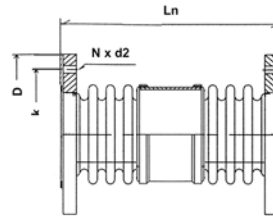

US2BU-03 type

code	nominal diameter [mm]	movement [± mm]		elasticity [N/mm]		Ln	D	k	N x d2
		axial	lateral	axial	lateral				
BM-US2SU-03-0040-041-0	DN40	43	105	24	1	480	48.3	-	-
BM-US2SU-03-0050-038-0	DN50	46	105	27	1	480	60.3	-	-
BM-US2SU-03-0065-044-0	DN65	58	110	22	1	475	76.1	-	-
BM-US2SU-03-0080-048-0	DN80	59	105	25	1	485	88.9	-	-
BM-US2SU-03-0100-050-0	DN100	66	95	20	2	435	114.3	-	-
BM-US2SU-03-0125-055-0	DN125	70	95	34	5	490	139.7	-	-
BM-US2SU-03-0150-075-0	DN150	80	100	35	6	545	168.3	-	-
BM-US2SU-03-0175-075-0	DN175	80	95	39	9	545	193.7	-	-
BM-US2SU-03-0200-075-0	DN200	88	90	36	11	545	219.1	-	-
BM-US2SU-03-0250-075-0	DN250	84	75	43	20	545	273	-	-
BM-US2SU-03-0300-090-0	DN300	90	70	43	28	585	323.9	-	-
BM-US2FU-03-0040-043-0	DN40	43	105	24	1	430	150	110	4 x 18
BM-US2FU-03-0050-046-0	DN50	46	105	27	1	435	165	125	4 x 18
BM-US2FU-03-0065-058-0	DN65	58	110	22	1	430	185	145	4 x 18
BM-US2FU-03-0080-059-0	DN80	59	105	25	1	445	200	160	8 x 18
BM-US2FU-03-0100-066-0	DN100	66	95	20	2	395	220	180	8 x 18
BM-US2FU-03-0125-070-0	DN125	70	95	34	5	455	250	210	8 x 18
BM-US2FU-03-0150-080-0	DN150	80	100	35	6	490	285	240	8 x 22
BM-US2FU-03-0200-088-0	DN200	88	90	36	11	475	320	280	8 x 18
BM-US2FU-03-0250-084-0	DN250	84	75	43	20	475	375	335	12 x 18
BM-US2FU-03-0300-090-0	DN300	90	70	43	28	475	440	395	12 x 22
BM-US2BU-03-0040-043-0	DN40	43	105	24	1	430	150	110	4 x 18
BM-US2BU-03-0050-046-0	DN50	46	105	27	1	435	165	125	4 x 18
BM-US2BU-03-0065-058-0	DN65	58	110	22	1	430	185	145	4 x 18
BM-US2BU-03-0080-059-0	DN80	59	105	25	1	445	200	160	8 x 18
BM-US2BU-03-0100-066-0	DN100	66	95	20	2	395	220	180	8 x 18
BM-US2BU-03-0125-070-0	DN125	70	95	34	5	455	250	210	8 x 18
BM-US2BU-03-0150-080-0	DN150	80	100	35	6	490	285	240	8 x 22
BM-US2BU-03-0200-088-0	DN200	88	90	36	11	475	320	280	8 x 18
BM-US2BU-03-0250-084-0	DN250	84	75	43	20	475	375	335	12 x 18
BM-US2BU-03-0300-090-0	DN300	90	70	43	28	475	440	395	12 x 22

INDUSTRIAL HOSES - compensators

Steel compensators



US3 - PN 2.5

US3SU-03: Welding ends
US3FU-03: Fixed flanges according to DIN 86044
US3BU-03: Swivel flanges according to DIN 86044
Material: AISI 321
Flanges: Carbon steel
Welding ends: Carbon steel
Working temp.: Up to +550°C
Working press.: Up to 2.5 bar
 (apply the temperature correction factor for temperatures above +120°C)

Compensators designed for application in exhaust fumes systems to compensate axial and lateral movements.

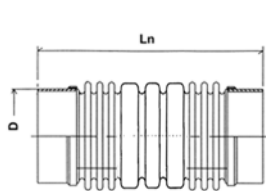

US3SU-03 type

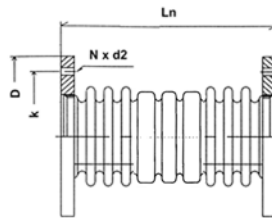

US3FU-03 type

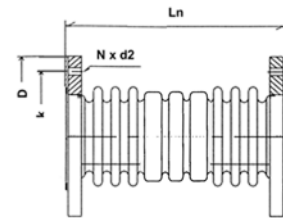

US3BU-03 type

code	nominal diameter [mm]	movement [± mm]		elasticity N/mm		Ln	D	k	N x d2
		axial	lateral	axial	lateral				
BM-US3SU-03-0040-030-0	DN40	30	73	49	2	375	48.3	-	-
BM-US3SU-03-0050-032-0	DN50	32	65	55	3	375	60.3	-	-
BM-US3SU-03-0065-040-0	DN65	54	54	57	5	345	76.1	-	-
BM-US3SU-03-0080-038-0	DN80	38	63	54	5	380	88.1	-	-
BM-US3SU-03-0100-036-0	DN100	36	46	52	11	330	114.3	-	-
BM-US3SU-03-0125-032-0	DN125	32	33	106	39	320	139.7	-	-
BM-US3SU-03-0150-045-0	DN150	45	46	90	33	395	168.3	-	-
BM-US3SU-03-0175-044-0	DN175	44	40	100	48	395	193.7	-	-
BM-US3SU-03-0200-049-0	DN200	49	42	91	52	405	219.1	-	-
BM-US3SU-03-0250-047-0	DN250	47	33	111	97	405	273	-	-
BM-US3SU-03-0300-050-0	DN300	50	26	110	182	415	323.9	-	-
BM-US3FU-03-0040-030-0	DN40	30	73	49	2	325	150	110	4 x 18
BM-US3FU-03-0050-031-0	DN50	32	65	55	3	330	165	125	4 x 18
BM-US3FU-03-0065-054-0	DN65	54	54	57	5	300	185	145	4 x 18
BM-US3FU-03-0080-038-0	DN80	38	63	54	5	340	200	160	8 x 18
BM-US3FU-03-0100-036-0	DN100	36	46	52	11	290	220	180	8 x 18
BM-US3FU-03-0125-032-0	DN125	32	33	106	39	285	250	210	8 x 18
BM-US3FU-03-0150-045-0	DN150	45	46	90	33	340	285	240	8 x 22
BM-US3FU-03-0200-049-0	DN200	49	42	91	52	335	320	280	8 x 18
BM-US3FU-03-0250-047-0	DN250	47	33	111	97	335	375	335	12 x 18
BM-US3FU-03-0300-050-0	DN300	50	26	110	182	310	440	395	12 x 22
BM-US3BU-03-0040-030-0	DN40	30	73	49	2	275	150	110	4 x 18
BM-US3BU-03-0050-032-0	DN50	32	65	55	3	275	165	125	4 x 18
BM-US3BU-03-0065-054-0	DN65	54	54	57	5	275	185	145	4 x 18
BM-US3BU-03-0080-038-0	DN80	38	63	54	5	340	200	160	8 x 18
BM-US3BU-03-0100-036-0	DN100	36	46	52	11	290	220	180	8 x 18
BM-US3BU-03-0125-032-0	DN125	32	33	106	39	285	250	210	8 x 18
BM-US3BU-03-0150-045-0	DN150	45	46	90	33	340	285	240	8 x 22
BM-US3BU-03-0200-049-0	DN200	49	42	91	52	335	320	280	8 x 18
BM-US3BU-03-0250-047-0	DN250	47	33	111	97	335	375	335	12 x 18
BM-US3BU-03-0300-050-0	DN300	50	26	110	182	310	440	395	12 x 22

INDUSTRIAL HOSES - compensators

Steel compensators



AN1 H - PN 10

AN1SH-10: Welding ends
AN1FH-10: Fixed flanges
Material: AISI 321
Flanges: Carbon steel
Welding ends: Carbon steel
Working temp.: Up to +550°C
Working press.: Up to 10 bar
 (apply the temperature correction factor for temperatures above +120°C)

Compensators designed for application in pipelines to compensate angular movements.

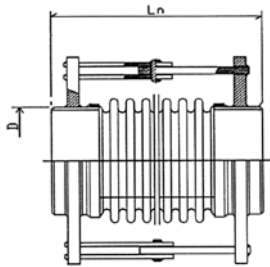

AN1SH-10 type

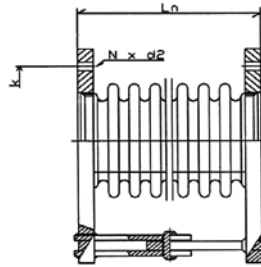

AN1FH-10 type

code	nominal diameter [mm]	angular movement [± deg]	angular elasticity [Nmm/deg]	Ln	D	k	N x d2
BM-AN1SH-10-0040-015-0	DN40	15	1040	300	48.3	-	-
BM-AN1SH-10-0050-015-0	DN50	15	1780	300	60.3	-	-
BM-AN1SH-10-0065-015-0	DN65	15	2347	295	76.1	-	-
BM-AN1SH-10-0080-015-0	DN80	15	4705	320	88.9	-	-
BM-AN1SH-10-0100-015-0	DN100	15	7385	315	114.3	-	-
BM-AN1SH-10-0125-015-0	DN125	15	10537	315	139.7	-	-
BM-AN1SH-10-0150-015-0	DN150	15	17676	315	168.3	-	-
BM-AN1SH-10-0175-014-0	DN175	14	25723	315	193.7	-	-
BM-AN1SH-10-0200-014-0	DN200	14	30330	315	219.1	-	-
BM-AN1SH-10-0250-010-0	DN250	10	56715	335	273	-	-
BM-AN1SH-10-0300-009-0	DN300	9	119553	340	323.9	-	-
BM-AN1FH-10-0040-015-0	DN40	15	1040	95	-	110	4 x 18
BM-AN1FH-10-0050-015-0	DN50	15	1780	95	-	125	4 x 18
BM-AN1FH-10-0065-015-0	DN65	15	2347	90	-	145	4 x 18
BM-AN1FH-10-0080-015-0	DN80	15	4705	115	-	160	8 x 18
BM-AN1FH-10-0100-015-0	DN100	15	7385	110	-	180	8 x 18
BM-AN1FH-10-0125-015-0	DN125	15	10537	115	-	210	8 x 18
BM-AN1FH-10-0150-015-0	DN150	15	17676	120	-	240	8 x 22
BM-AN1FH-10-0175-014-0	DN175	14	25723	120	-	270	8 x 22
BM-AN1FH-10-0200-014-0	DN200	14	30330	130	-	295	8 x 22
BM-AN1FH-10-0250-010-0	DN250	10	56715	130	-	350	12 x 22
BM-AN1FH-10-0300-009-0	DN300	9	119553	145	-	400	12 x 22

INDUSTRIAL HOSES - compensators

Steel compensators



AN1 K - PN 10

AN1SK-10: Welding ends
AN1FK-10: Fixed flanges
Material: AISI 321
Flanges: Carbon steel
Welding ends: Carbon steel
Working temp.: Up to +550°C
Working press.: Up to 10 bar
 (apply the temperature correction factor for temperatures above +120°C)

Compensators designed for application in pipelines to compensate angular movements.

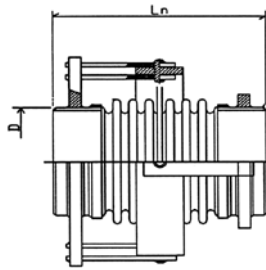

AN1SK-10 type

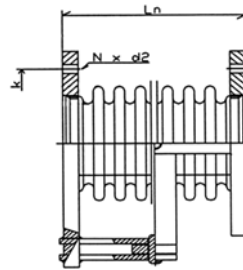

AN1FK-10 type

code	nominal diameter [mm]	angular movement [± deg]	angular elasticity [Nmm/deg]	Ln	D	k	N x d2
BM-AN1SK-10-0040-015-0	DN40	15	1040	300	48.3	-	-
BM-AN1SK-10-0050-015-0	DN50	15	1780	300	60.3	-	-
BM-AN1SK-10-0065-015-0	DN65	15	2347	295	76.1	-	-
BM-AN1SK-10-0080-015-0	DN80	15	4705	320	88.9	-	-
BM-AN1SK-10-0100-015-0	DN100	15	7385	315	114.3	-	-
BM-AN1SK-10-0125-015-0	DN125	15	10537	310	139.7	-	-
BM-AN1SK-10-0150-015-0	DN150	15	17676	315	168.3	-	-
BM-AN1SK-10-0175-014-0	DN175	14	25723	315	193.7	-	-
BM-AN1SK-10-0200-014-0	DN200	14	30330	315	219.1	-	-
BM-AN1SK-10-0250-010-0	DN250	10	56715	335	273	-	-
BM-AN1SK-10-0300-009-0	DN300	9	119553	340	323.9	-	-
BM-AN1FK-10-0040-015-0	DN40	15	1040	95	-	110	4 x 18
BM-AN1FK-10-0050-015-0	DN50	15	1780	95	-	125	4 x 18
BM-AN1FK-10-0065-015-0	DN65	15	2347	90	-	145	4 x 18
BM-AN1FK-10-0080-015-0	DN80	15	4705	115	-	160	8 x 18
BM-AN1FK-10-0100-015-0	DN100	15	7385	110	-	180	8 x 18
BM-AN1FK-10-0125-015-0	DN125	15	10537	115	-	210	8 x 18
BM-AN1FK-10-0150-015-0	DN150	15	17676	120	-	240	8 x 22
BM-AN1FK-10-0175-014-0	DN175	14	25723	120	-	270	8 x 22
BM-AN1FK-10-0200-014-0	DN200	14	30330	130	-	295	8 x 22
BM-AN1FK-10-0250-010-0	DN250	10	56715	130	-	350	12 x 22
BM-AN1FK-10-0300-009-0	DN300	9	119553	145	-	400	12 x 22

INDUSTRIAL HOSES - compensators

Steel compensators



AX1 - PN 10

AX1SU-10: Welding ends
AX1FU-10: Fixed flanges according to DIN 2576
Material: AISI 321
Flanges: Carbon steel
Welding ends: Carbon steel
Working temp.: Up to +550°C
Working press.: Up to 10 bar
 (apply the temperature correction factor for temperatures above +120°C)

Axial compensators designed for application in pipelines to compensate axial and lateral movements.

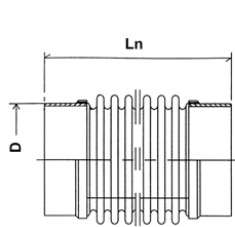

AX1SU-10 type

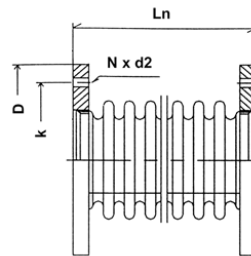

AX1FU-10 type

code	nominal diameter [mm]	movement [± mm]		elasticity [N/mm]		Ln	D	k	N x d2
		axial	lateral	axial	lateral				
BM-AX1SU-10-0040-013-0	DN 40	13	7	135	83	160	48.3	-	-
BM-AX1SU-10-0050-014-0	DN 50	14	6	150	141	160	60.3	-	-
BM-AX1SU-10-0065-018-0	DN 65	18	6	123	193	160	76.1	-	-
BM-AX1SU-10-0080-022-0	DN 80	22	8	183	237	180	88.9	-	-
BM-AX1SU-10-0100-022-0	DN 100	22	6	169	407	175	114.3	-	-
BM-AX1SU-10-0125-025-0	DN 125	25	5	161	595	170	139.7	-	-
BM-AX1SU-10-0150-025-0	DN 150	25	4	193	974	195	168.3	-	-
BM-AX1SU-10-0175-025-0	DN 175	25	4	212	1418	195	193.7	-	-
BM-AX1SU-10-0200-027-0	DN 200	27	3	195	1703	195	219.1	-	-
BM-AX1SU-10-0250-026-0	DN 250	26	3	236	3184	195	273	-	-
BM-AX1SU-10-0300-028-0	DN 300	28	2	351	5941	240	323.9	-	-
BM-AX1FU-10-0040-013-0	DN 40	13	7	135	83	110	150	110	4 x 18
BM-AX1FU-10-0050-014-0	DN 50	14	6	150	141	115	165	125	4 x 18
BM-AX1FU-10-0065-018-0	DN 65	18	6	123	193	115	185	145	4 x 18
BM-AX1FU-10-0080-022-0	DN 80	22	8	183	237	140	200	160	8 x 18
BM-AX1FU-10-0100-022-0	DN 100	22	6	169	407	135	220	180	8 x 18
BM-AX1FU-10-0125-025-0	DN 125	25	5	161	595	135	250	210	8 x 18
BM-AX1FU-10-0150-025-0	DN 150	25	4	193	974	140	285	240	8 x 22
BM-AX1FU-10-0175-025-0	DN 175	25	4	212	1418	145	315	270	8 x 22
BM-AX1FU-10-0200-027-0	DN 200	27	3	195	1703	145	340	295	8 x 22
BM-AX1FU-10-0250-026-0	DN 250	26	3	236	3184	145	395	350	12 x 22
BM-AX1FU-10-0300-028-0	DN 300	28	2	351	5941	150	445	400	12 x 22

INDUSTRIAL HOSES - compensators

Steel compensators



LA1 - PN 10

LA1ST-10: Welding ends
LA1FT-10: Fixed flanges
Material: AISI 321
Flanges: Carbon steel
Welding ends: Carbon steel
Working temp.: Up to +550°C
Working press.: Up to 10 bar
 (apply the temperature correction factor for temperatures above +120°C)

Compensators designed for application in pipelines to compensate lateral movements.

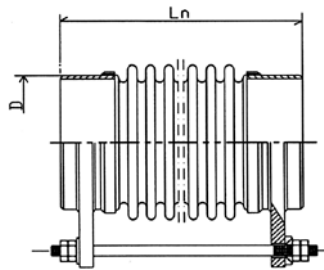

LA1ST-10 type

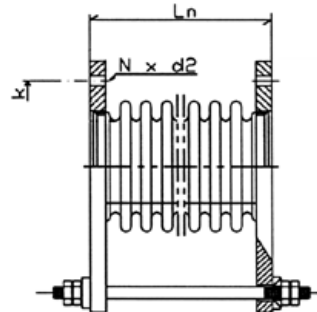

LA1FT-10 type

code	nominal diameter [mm]	lateral movement [± mm]	elasticity [N/mm]		Ln	D	k	N x d2
			axial	lateral				
BM-LA1ST-10-0040-030-0	DN40	30	63	10	445	48.3	-	-
BM-LA1ST-10-0050-025-0	DN50	25	70	17	445	60.3	-	-
BM-LA1ST-10-0065-025-0	DN65	25	57	22	440	76.1	-	-
BM-LA1ST-10-0080-033-0	DN80	33	85	28	485	88.9	-	-
BM-LA1ST-10-0100-025-0	DN100	25	79	48	475	114.3	-	-
BM-LA1ST-10-0125-022-0	DN125	22	75	71	475	139.7	-	-
BM-LA1ST-10-0150-020-0	DN150	20	88	112	475	168.3	-	-
BM-LA1ST-10-0175-017-0	DN175	17	97	163	475	193.7	-	-
BM-LA1ST-10-0200-016-0	DN200	16	88	197	525	219.1	-	-
BM-LA1ST-10-0250-017-0	DN250	17	91	229	555	273.3	-	-
BM-LA1ST-10-0300-022-0	DN300	22	117	283	600	323.9	-	-
BM-LA1FT-10-0040-030-0	DN40	30	63	10	185	150	110	4 x 18
BM-LA1FT-10-0050-025-0	DN50	25	70	17	190	165	125	4 x 18
BM-LA1FT-10-0065-025-0	DN65	25	57	22	190	185	145	4 x 18
BM-LA1FT-10-0080-033-0	DN80	33	85	28	235	200	160	8 x 18
BM-LA1FT-10-0100-025-0	DN100	25	79	48	225	220	180	8 x 18
BM-LA1FT-10-0125-022-0	DN125	22	75	71	225	250	210	8 x 18
BM-LA1FT-10-0150-020-0	DN150	20	88	112	230	285	240	8 x 22
BM-LA1FT-10-0175-017-0	DN175	17	97	163	235	315	270	8 x 22
BM-LA1FT-10-0200-016-0	DN200	16	88	197	230	340	295	8 x 22
BM-LA1FT-10-0250-017-0	DN250	17	91	229	265	395	350	12 x 22
BM-LA1FT-10-0300-022-0	DN300	22	117	283	310	445	400	12 x 22

INDUSTRIAL HOSES - compensators

Steel compensators



LA2 - PN 10

LA2ST-10: Welding ends
LA2FT-10: Fixed flanges
Material: AISI 321
Flanges: Carbon steel
Welding ends: Carbon steel
Working temp.: Up to +550°C
Working press.: Up to 10 bar
 (apply the temperature correction factor for temperatures above +120°C)

Compensators designed for application in pipelines to compensate lateral movements.

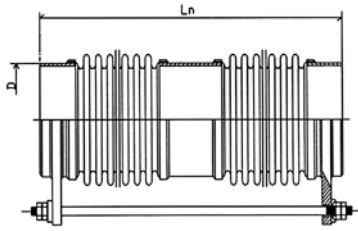

LA2ST-10 type

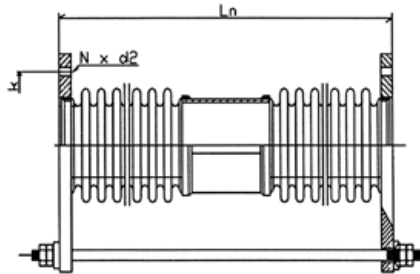

LA2FT-10 type

code	nominal diameter [mm]	lateral movement [± mm]	elasticity [N/mm]		Ln	D	k	N x d2
			axial	lateral				
BM-LA2ST-10-0040-075-0	DN40	75	68	1	620	48.3	-	-
BM-LA2ST-10-0050-075-0	DN50	75	75	2	630	60.3	-	-
BM-LA2ST-10-0065-075-0	DN65	75	61	3	615	76.1	-	-
BM-LA2ST-10-0080-075-0	DN80	75	92	7	615	88.9	-	-
BM-LA2ST-10-0100-075-0	DN100	75	85	8	645	114.3	-	-
BM-LA2ST-10-0125-075-0	DN125	75	81	11	660	139.7	-	-
BM-LA2ST-10-0150-075-0	DN150	75	96	14	700	168.3	-	-
BM-LA2ST-10-0175-075-0	DN175	75	106	16	745	193.7	-	-
BM-LA2ST-10-0200-075-0	DN200	75	97	18	805	219.1	-	-
BM-LA2ST-10-0250-055-0	DN250	55	118	41	765	273.3	-	-
BM-LA2ST-10-0300-055-0	DN300	55	176	82	780	323.9	-	-
BM-LA2FT-10-0040-075-0	DN40	75	97	2	360	150	110	4 x 18
BM-LA2FT-10-0050-075-0	DN50	75	107	3	375	165	125	4 x 18
BM-LA2FT-10-0065-075-0	DN65	75	87	4	360	185	145	4 x 18
BM-LA2FT-10-0080-075-0	DN80	75	131	10	365	200	160	8 x 18
BM-LA2FT-10-0100-075-0	DN100	75	121	12	395	220	180	8 x 18
BM-LA2FT-10-0125-075-0	DN125	75	115	16	415	250	210	8 x 18
BM-LA2FT-10-0150-075-0	DN150	75	137	20	455	285	240	8 x 22
BM-LA2FT-10-0175-075-0	DN175	75	152	23	505	315	270	8 x 22
BM-LA2FT-10-0200-075-0	DN200	75	139	25	515	340	295	8 x 22
BM-LA2FT-10-0250-055-0	DN250	55	169	59	475	395	350	12 x 22
BM-LA2FT-10-0300-055-0	DN300	55	251	117	490	445	400	12 x 22

INDUSTRIAL HOSES - compensators

Steel compensators



AN1 H - PN 16

AN1SH-16: Welding ends
AN1FH-16: Fixed flanges
Material: AISI 321
Flanges: Carbon steel
Welding ends: Carbon steel
Working temp.: Up to +550°C
Working press.: Up to 16 bar
 (apply the temperature correction factor for temperatures above +120°C)

Compensators designed for application in pipelines to compensate angular movements.

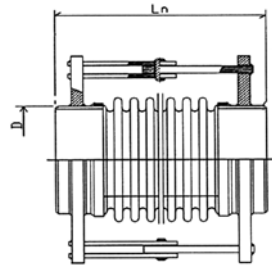

AN1SH-16 type

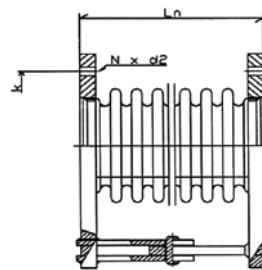

AN1FH-16 type

code	nominal diameter [mm]	angular movement [± deg]	angular elasticity [Nmm/deg]	Ln	D	k	N x d2
BM-AN1SH-16-0040-015-0	DN40	15	2112	300	48.3	-	-
BM-AN1SH-16-0050-015-0	DN50	15	3682	300	60.3	-	-
BM-AN1SH-16-0065-015-0	DN65	15	5012	300	76.1	-	-
BM-AN1SH-16-0080-015-0	DN80	15	6078	315	88.9	-	-
BM-AN1SH-16-0100-015-0	DN100	15	10339	290	114.3	-	-
BM-AN1SH-16-0125-015-0	DN125	15	22540	295	139.7	-	-
BM-AN1SH-16-0150-015-0	DN150	15	27634	320	168.3	-	-
BM-AN1SH-16-0175-014-0	DN175	14	39846	340	193.7	-	-
BM-AN1SH-16-0200-014-0	DN200	14	63942	345	219.1	-	-
BM-AN1SH-16-0250-011-0	DN250	11	114879	345	273	-	-
BM-AN1SH-16-0300-010-0	DN300	10	159735	345	323.9	-	-
BM-AN1FH-16-0040-015-0	DN40	15	2112	95	-	110	4 x 18
BM-AN1FH-16-0050-015-0	DN50	15	3682	95	-	125	4 x 18
BM-AN1FH-16-0065-015-0	DN65	15	5012	95	-	145	4 x 18
BM-AN1FH-16-0080-015-0	DN80	15	6078	110	-	160	8 x 18
BM-AN1FH-16-0100-015-0	DN100	15	10339	95	-	180	8 x 18
BM-AN1FH-16-0125-015-0	DN125	15	22540	100	-	210	8 x 18
BM-AN1FH-16-0150-015-0	DN150	15	27634	135	-	240	8 x 22
BM-AN1FH-16-0175-014-0	DN175	14	39846	135	-	270	8 x 22
BM-AN1FH-16-0200-014-0	DN200	14	63942	140	-	295	12 x 22
BM-AN1FH-16-0250-011-0	DN250	11	114879	150	-	355	12 x 26
BM-AN1FH-16-0300-010-0	DN300	10	159735	160	-	410	12 x 26

INDUSTRIAL HOSES - compensators

Steel compensators



AN1 K - PN 16

AN1SK-16: Welding ends
AN1FK-16: Fixed flanges
Material: AISI 321
Flanges: Carbon steel
Welding ends: Carbon steel
Working temp.: Up to +550°C
Working press.: Up to 16 bar
 (apply the temperature correction factor for temperatures above +120°C)

Compensators designed for application in pipelines to compensate angular movements.

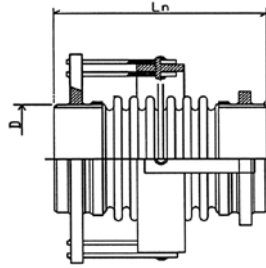

AN1SK-16 type

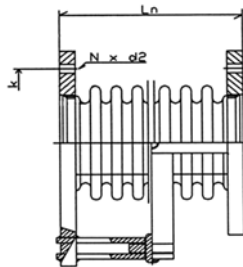

AN1FK-16 type

code	nominal diameter [mm]	angular movement [± deg]	angular elasticity [Nmm/deg]	Ln	D	k	N x d2
BM-AN1SK-16-0040-015-0	DN40	15	2112	300	48.3	-	-
BM-AN1SK-16-0050-015-0	DN50	15	3682	300	60.3	-	-
BM-AN1SK-16-0065-015-0	DN65	15	5012	300	76.1	-	-
BM-AN1SK-16-0080-015-0	DN80	15	6078	315	88.9	-	-
BM-AN1SK-16-0100-015-0	DN100	15	10339	290	114.3	-	-
BM-AN1SK-16-0125-015-0	DN125	15	22540	295	139.7	-	-
BM-AN1SK-16-0150-015-0	DN150	15	27634	320	168.3	-	-
BM-AN1SK-16-0175-014-0	DN175	14	39846	340	193.7	-	-
BM-AN1SK-16-0200-014-0	DN200	14	63960	345	219.1	-	-
BM-AN1SK-16-0250-011-0	DN250	11	114879	345	273	-	-
BM-AN1SK-16-0300-010-0	DN300	10	159735	345	323.9	-	-
BM-AN1FK-16-0040-015-0	DN40	15	2112	95	-	110	4 x 18
BM-AN1FK-16-0050-015-0	DN50	15	3682	95	-	125	4 x 18
BM-AN1FK-16-0065-015-0	DN65	15	5012	95	-	145	4 x 18
BM-AN1FK-16-0080-015-0	DN80	15	6078	110	-	160	8 x 18
BM-AN1FK-16-0100-015-0	DN100	15	10339	95	-	180	8 x 18
BM-AN1FK-16-0125-015-0	DN125	15	22540	100	-	210	8 x 18
BM-AN1FK-16-0150-015-0	DN150	15	27634	135	-	240	8 x 22
BM-AN1FK-16-0175-014-0	DN175	14	39846	135	-	270	8 x 22
BM-AN1FK-16-0200-014-0	DN200	14	63942	140	-	295	12 x 22
BM-AN1FK-16-0250-011-0	DN250	11	114879	150	-	355	12 x 26
BM-AN1FK-16-0300-010-0	DN300	10	159735	160	-	410	12 x 26

INDUSTRIAL HOSES - compensators

Steel compensators



AX1 - PN 16

AX1SU-16: Welding ends
AX1FU-16: Flanges according to DIN 2576
AX1HU-16: Flanges according to DIN 2633
Material: AISI 321
Flanges: Carbon steel
Welding ends: Carbon steel
Working temp.: Up to +550°C
Working press.: Up to 16 bar
 (apply the temperature correction factor for temperatures above +120°C)

Axial compensators designed for application in pipelines to compensate axial and lateral movements.

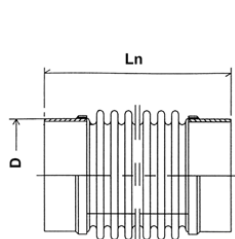

AX1SU-16 type

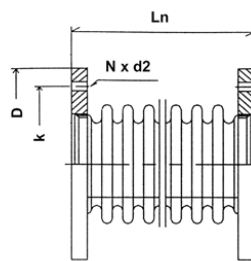

AX1FU-16 type

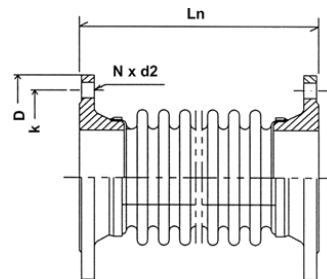

AX1HU-16 type

code	nominal diameter [mm]	movement [± mm]		elasticity [N/mm]		Ln	D	k	N x d2
		axial	lateral	axial	lateral				
BM-AX1SU-16-0040-011-0	DN 40	11	6	270	154	160	48.3	-	-
BM-AX1SU-16-0050-012-0	DN 50	12	5	307	269	160	60.3	-	-
BM-AX1SU-16-0065-013-0	DN 65	13	5	258	377	160	76.1	-	-
BM-AX1SU-16-0080-017-0	DN 80	17	6	237	318	175	88.9	-	-
BM-AX1SU-16-0100-015-0	DN 100	15	3	237	1004	150	114.3	-	-
BM-AX1SU-16-0125-018-0	DN 125	18	3	341	1945	155	139.7	-	-
BM-AX1SU-16-0150-025-0	DN 150	25	5	298	1368	200	168.3	-	-
BM-AX1SU-16-0175-025-0	DN-175	25	4	326	2057	200	193.7	-	-
BM-AX1SU-16-0200-028-0	DN 200	28	4	404	2907	205	219.1	-	-
BM-AX1SU-16-0250-028-0	DN 250	28	3	473	5223	205	273	-	-
BM-AX1SU-16-0300-029-0	DN 300	29	3	467	7177	245	323.9	-	-
BM-AX1FU-16-0040-011-0	DN 40	11	6	270	154	110	150	110	4 x 18
BM-AX1FU-16-0050-012-0	DN 50	12	5	307	269	115	165	125	4 x 18
BM-AX1FU-16-0065-013-0	DN 65	13	5	258	377	115	185	145	4 x 18
BM-AX1FU-16-0080-017-0	DN 80	17	6	237	318	135	200	160	8 x 18
BM-AX1FU-16-0100-015-0	DN 100	15	3	237	1004	110	220	180	8 x 18
BM-AX1FU-16-0125-018-0	DN 125	18	3	341	1945	120	250	210	8 x 18
BM-AX1FU-16-0150-025-0	DN 150	25	5	298	1368	145	285	240	8 x 22
BM-AX1FU-16-0175-025-0	DN-175	25	4	326	2057	145	315	270	8 x 22
BM-AX1HU-16-0200-028-0	DN 200	28	4	404	2907	150	340	295	12 x 22
BM-AX1HU-16-0250-028-0	DN 250	28	3	473	5223	245	405	355	12 x 26
BM-AX1HU-16-0300-029-0	DN 300	29	3	467	7177	260	460	410	12 x 26

INDUSTRIAL HOSES - compensators

Steel compensators



LA1 - PN 16

LA1ST-16: Welding ends
LA1FT-16: Fixed flanges
Material: AISI 321
Flanges: Carbon steel
Welding ends: Carbon steel
Working temp.: Up to +550°C
Working press.: Up to 16 bar
 (apply the temperature correction factor for temperatures above +120°C)

Compensators designed for application in pipelines to compensate lateral movements.

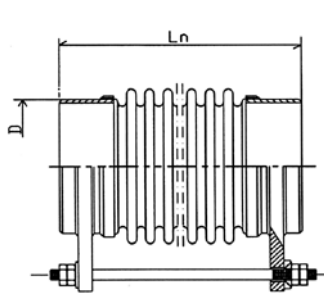

LA1ST-16 type

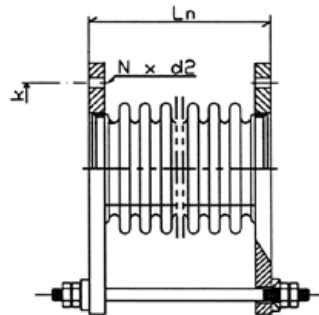

LA1FT-16 type

code	nominal diameter [mm]	lateral movement [± mm]	elasticity [N/mm]		Ln	D	k	N x d2
			axial	lateral				
BM-LA1ST-16-0040-026-0	DN40	26	126	18	450	48.3	-	-
BM-LA1ST-16-0050-025-0	DN50	25	143	32	450	60.3	-	-
BM-LA1ST-16-0065-020-0	DN65	20	120	44	450	76.1	-	-
BM-LA1ST-16-0080-026-0	DN80	26	111	37	480	88.9	-	-
BM-LA1ST-16-0100-018-0	DN100	18	91	72	455	114.3	-	-
BM-LA1ST-16-0125-025-0	DN125	25	113	93	485	139.7	-	-
BM-LA1ST-16-0150-021-0	DN150	21	136	158	485	168.3	-	-
BM-LA1ST-16-0175-018-0	DN175	18	148	227	485	193.7	-	-
BM-LA1ST-16-0200-018-0	DN200	18	183	335	495	219.1	-	-
BM-LA1ST-16-0250-020-0	DN250	20	181	375	580	273	-	-
BM-LA1ST-16-0300-024-0	DN300	24	155	341	615	323.9	-	-
BM-LA1FT-16-0040-026-0	DN40	26	126	18	195	150	110	4 x 18
BM-LA1FT-16-0050-025-0	DN50	25	143	32	200	165	125	4 x 18
BM-LA1FT-16-0065-020-0	DN65	20	120	44	195	185	145	4 x 18
BM-LA1FT-16-0080-026-0	DN80	26	111	37	230	200	160	8 x 18
BM-LA1FT-16-0100-018-0	DN100	18	91	72	205	220	180	8 x 18
BM-LA1FT-16-0125-025-0	DN125	25	113	93	240	250	210	8 x 18
BM-LA1FT-16-0150-021-0	DN150	21	136	158	240	285	240	8 x 22
BM-LA1FT-16-0175-018-0	DN175	18	148	227	245	315	270	8 x 22
BM-LA1FT-16-0200-018-0	DN200	18	183	335	330	340	295	12 x 22
BM-LA1FT-16-0250-020-0	DN250	20	181	375	380	405	355	12 x 26
BM-LA1FT-16-0300-024-0	DN300	24	155	341	430	460	410	12 x 26

INDUSTRIAL HOSES - compensators

Steel compensators



LA2 - PN 16

LA2ST-16: Welding ends
LA2FT-16: Fixed flanges
Material: AISI 321
Flanges: Carbon steel
Welding ends: Carbon steel
Working temp.: Up to +550°C
Working press.: Up to 16 bar
 (apply the temperature correction factor for temperatures above +120°C)

Compensators designed for application in pipelines to compensate lateral movements.

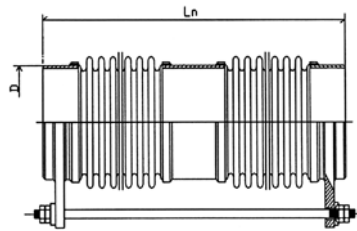

LA2ST-16 type

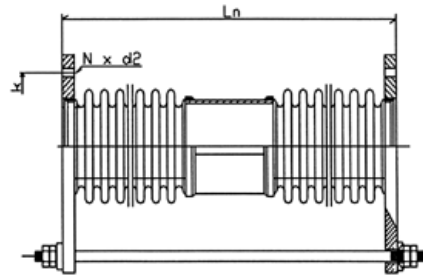

LA2FT-16 type

code	nominal diameter [mm]	lateral movement [± mm]	elasticity [N/mm]		Ln	D	k	N x d2
			axial	lateral				
BM-LA2ST-16-0040-075-0	DN40	75	135	2	670	48.3	-	-
BM-LA2ST-16-0050-075-0	DN50	75	153	3	690	60.3	-	-
BM-LA2ST-16-0065-075-0	DN65	75	130	4	695	76.1	-	-
BM-LA2ST-16-0080-075-0	DN80	75	118	6	670	88.9	-	-
BM-LA2ST-16-0100-075-0	DN100	75	119	6	740	114.3	-	-
BM-LA2ST-16-0125-075-0	DN125	75	171	13	740	139.7	-	-
BM-LA2ST-16-0150-075-0	DN150	75	149	22	705	168.3	-	-
BM-LA2ST-16-0175-075-0	DN175	75	163	25	745	193.7	-	-
BM-LA2ST-16-0200-075-0	DN200	75	202	42	745	219.1	-	-
BM-LA2ST-16-0250-055-0	DN250	55	236	102	745	273	-	-
BM-LA2ST-16-0300-055-0	DN300	55	233	113	780	323.9	-	-
BM-LA2FT-16-0040-075-0	DN40	75	193	3	410	150	110	4 x 18
BM-LA2FT-16-0050-075-0	DN50	75	219	4	435	165	125	4 x 18
BM-LA2FT-16-0065-075-0	DN65	75	185	5	440	185	145	4 x 18
BM-LA2FT-16-0080-075-0	DN80	75	169	9	420	200	160	8 x 18
BM-LA2FT-16-0100-075-0	DN100	75	170	8	490	220	180	8 x 18
BM-LA2FT-16-0125-075-0	DN125	75	244	18	495	250	210	8 x 18
BM-LA2FT-16-0150-075-0	DN150	75	213	32	460	285	240	8 x 22
BM-LA2FT-16-0175-075-0	DN175	75	233	36	505	315	270	8 x 22
BM-LA2FT-16-0200-075-0	DN200	75	289	60	580	340	295	12 x 22
BM-LA2FT-16-0250-055-0	DN250	55	337	145	545	405	355	12 x 26
BM-LA2FT-16-0300-055-0	DN300	55	333	162	595	460	410	12 x 26

INDUSTRIAL HOSES - compensators

PTFE compensators

Working parameters of PTFE compensators

The working parameters of compensators listed in the tables (working pressure, temperature) are the maximum values and must not occur simultaneously. At elevated temperatures, it is required to reduce the values given in the table regarding the maximum working pressure. Please contact Sales or Technical Department of TUBES INTERNATIONAL® in the event of any doubts concerning permissible working parameters of the compensator in particular application.

compensator type	working \ temperature	maximum working pressure [bar]		
		2 ÷ 3 convolutions	4 ÷ 6 convolutions	7 ÷ 10 convolutions
R-LD	+50°C	6	2.5	1
	+100°C	4.5	2	0.7
	+235°C	1	0	0*)
R	+50°C	10	6	2.5
	+100°C	8	4.5	2
	+235°C	2	1	0
R-HD	+50°C	16	10	6
	+100°C	12.5	8	4.5
	+235°C	3	2	1



INDUSTRIAL HOSES - compensators

PTFE compensators



R-LD, R, R-HD type

Material: PTFE (also antistatic)
Reinforcement: Stainless steel rings
Flanges: Ductile cast iron GGG 40 with tie rods
Working temp.: Up to +235°C

PTFE compensators are made of helically corrugated bellow finished with flanges. Reinforced with external rings made of stainless steel. Flanges made according to ASA and DIN standards. Special versions are also available: double walled bellow with a draining system, with carbon steel or stainless steel flanges, with reinforcing rings made of Monel 400 or Hastelloy N4, with internal pilot ferrule.

Due to such advantages as good flexibility of connection, very good chemical and thermal resistance and self-cleaning properties they are widely used in chemical, food and pharmaceutical industry.

R-LD type 6 bar

code	DN [mm]	length [mm]			axial movement / convolution [± mm]	lateral movement / convolution [± mm]	angular movement / convolution [± mm]
		two convolution bellow	three convolution bellow	any additional convolution +			
TG-R-LD-025-*	25	45	55	12	5.5	3.5	8
TG-R-LD-032-*	32	55	65	13	5.5	3.5	7.5
TG-R-LD-040-*	40	55	70	15	6	4	7.5
TG-R-LD-050-*	50	60	70	16	6	4	6.5
TG-R-LD-065-*	65	60	80	20	6.5	5	6
TG-R-LD-080-*	80	65	90	24	6.5	5	6
TG-R-LD-100-*	100	70	95	25	7.5	5.5	5.5
TG-R-LD-125-*	125	75	100	25	8	5.5	5
TG-R-LD-150-*	150	75	105	25	8.5	5.5	4
TG-R-LD-200-*	200	80	110	25	9	6	3.5
TG-R-LD-250-*	250	90	120	26	10	6	3.5
TG-R-LD-300-*	300	95	125	26	10	6	3
TG-R-LD-350-*	350	100	125	26	10.5	6	3
TG-R-LD-400-*	400	100	135	26	10.5	6	2.5
TG-R-LD-500-*	500	105	140	26	11	6.5	2.5
TG-R-LD-600-*	600	105	140	26	11	6.5	2

INDUSTRIAL HOSES - compensators

PTFE compensators

R type 10 bar

code	DN [mm]	length [mm]			axial movement / convolution [± mm]	lateral movement / convolution [± mm]	angular movement / convolution [± mm]
		two convolution bellow	three convolution bellow	any additional convolution +			
TG-R-025-*	25	45	55	12	4.5	3	6.5
TG-R-032-*	32	55	65	13	4.5	3	6
TG-R-040-*	40	55	70	15	5	3.5	6
TG-R-050-*	50	60	70	16	5	3.5	5.5
TG-R-065-*	65	60	80	20	5.5	4	5
TG-R-080-*	80	65	90	24	5.5	4	5
TG-R-100-*	100	70	95	25	6	4.5	4.5
TG-R-125-*	125	75	100	25	6.5	4.5	4
TG-R-150-*	150	75	105	25	7	4.5	3.5
TG-R-200-*	200	80	110	25	7.5	5	3
TG-R-250-*	250	90	120	26	8	5	3
TG-R-300-*	300	95	125	26	8	5	2.5
TG-R-350-*	350	100	125	26	8.5	5	2.5
TG-R-400-*	400	100	135	26	8.5	5	2
TG-R-500-*	500	105	140	26	9	5.5	2
TG-R-600-*	600	105	140	26	9	5.5	1.5

R-HD type 16 bar

code	DN [mm]	length [mm]			axial movement / convolution [± mm]	lateral movement / convolution [± mm]	angular movement / convolution [± mm]
		two convolution bellow	three convolution bellow	any additional convolution +			
TG-R-HD-025-*	25	45	55	12	3	2	4.5
TG-R-HD-032-*	32	55	65	13	3	2	4
TG-R-HD-040-*	40	55	70	15	3.5	2.5	4
TG-R-HD-050-*	50	60	70	16	3.5	2.5	3.5
TG-R-HD-065-*	65	60	80	20	4	3	3.5
TG-R-HD-080-*	80	65	90	24	4	3	3.5
TG-R-HD-100-*	100	70	95	25	4.5	3	3
TG-R-HD-125-*	125	75	100	25	4.5	3	3
TG-R-HD-150-*	150	75	105	25	5	3	2.5
TG-R-HD-200-*	200	80	110	25	5	3.5	2
TG-R-HD-250-*	250	90	120	26	5.5	3.5	2
TG-R-HD-300-*	300	95	125	26	5.5	3.5	1.5
TG-R-HD-350-*	350	100	125	26	6	3.5	1.5
TG-R-HD-400-*	400	100	135	26	6	3.5	1.5
TG-R-HD-500-*	500	105	140	26	6.5	4	1.5
TG-R-HD-600-*	600	105	140	26	6.5	4	1

NOTE!

* in code number refers to number of convolutions e.g. TB-R-300-3 refers to a "R" type compensator, DN 300 with 3 convolutions.

INDUSTRIAL HOSES - compensators

Fabric compensators

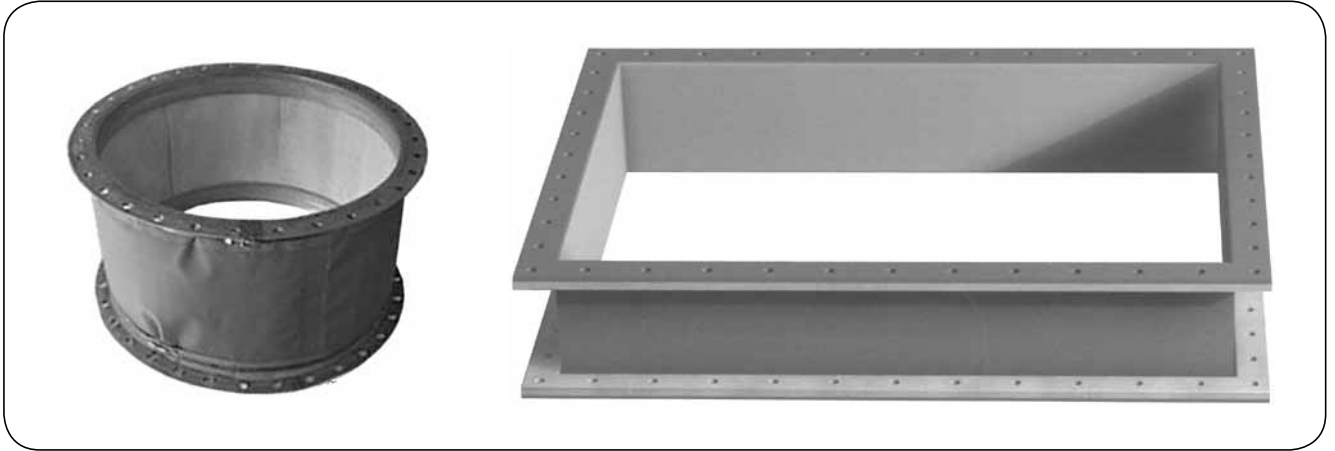

Fabric compensators are designed for cold and hot air installations, ventilation and air-conditioning systems, power plant exhaust fumes systems, to transfer loose products, etc.

Bellows of the compensators can be made of polyester or aramid fabric, fibreglass or ceramic fabric, fabric impregnated with EPDM rubber, Hypalon, silicone, Viton. All building materials are free of asbestos. The choice of adequate bellow material depends on the medium and its temperature (from +100°C up to +1000°C).

As textile materials are flexible and malleable they can be used to produce compensators of any cross-section e.g. circular, oval, rectangular. A set of layers, dimensions and shape of the compensator are selected individually for each item. Bellows can be flat, corrugated, with or without reinforcing rings, with diameter reduction, with flow liners. The liners are used to guide the stream inside the compensator. Recommended for abrasive products, at high flow rates, in high contamination of particulate media in order to reduce impurities build-up on the bellow walls.

Examples of fabric compensator design

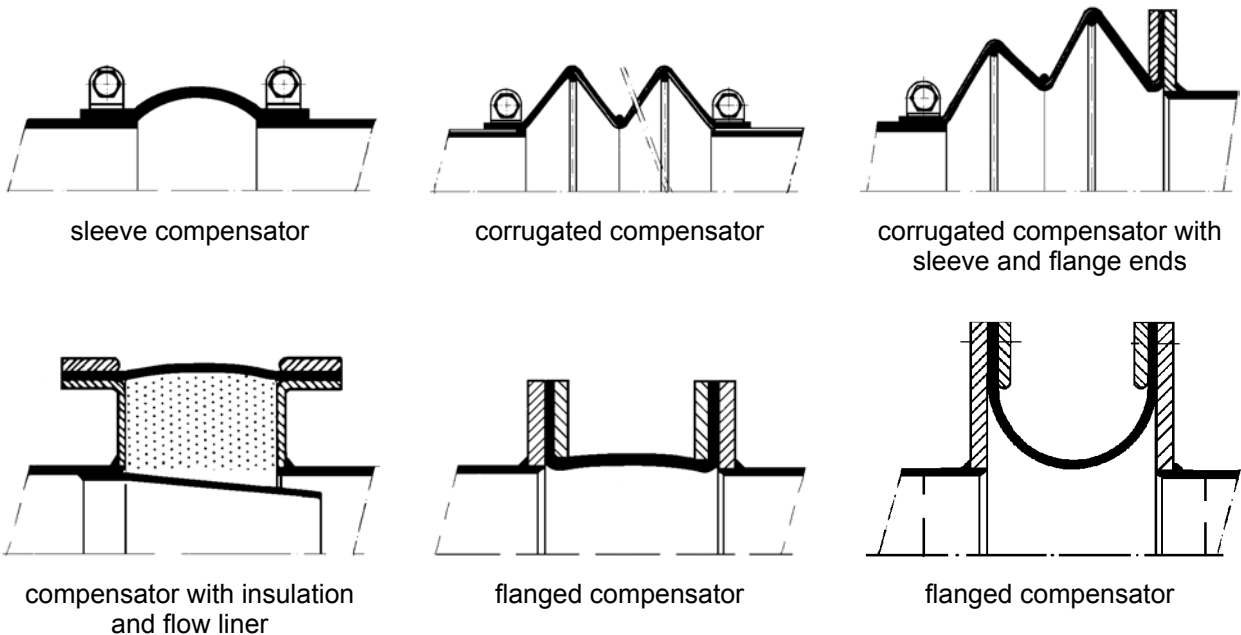

INDUSTRIAL HOSES - compensators

Elastomeric compensators

An elastomer is a synthetic or natural polymer material, with ability to return to its original shape after deformation caused by mechanical stress, without any damage to its structure. The group of elastomers comprises a wider variety of materials than rubber, which is only one of the classes within this group. The elastomer has the ability to undergo deformation in a wide range of its dimensions under the influence of tensile, shear or compressive force and regain its original dimensions once the force has been removed.

Elastomeric compensators are intended to work in constant working temperature reaching above +200°C (depending on a bellow material). Each compensator is made of an elastomeric material with one or more layers of reinforcement vulcanized together to form one robust and resistant material. There is no standard set of dimensions for this type of compensators so they can be freely manufactured in any shape or dimension. Available as round, rectangular or oval with length adjusted to fit the installation. The length of these compensators is not fixed as it depends on displacement that is to be absorbed by the compensator. This type of compensators is the best choice for the transfer of wet gases and exhaust in ducting of hot air or chimney installations. They can efficiently absorb multidirectional displacement and vibration of hose assemblies and any incidents of misalignment.

There are four basic materials used to make elastomeric compensators:

EPDM - Resistant to the influence of hot air, uncooled exhaust gases and weather conditions. Not intended for contact with fat, oils and petrochemicals. Suitable for installations with a constant working temperature up to +120°C and working pressure up to 50 kPa.

FKM (Viton B) - Excellent resistance to chemicals and high temperature. Resistant to the chemical impact of mineral oil and acid particles contained in exhausts as well as sulphur compounds (SO and H₂S) in carbon and mineral oil exhausts. Suitable for dry and wet installations with a constant working temperature up to +200°C and working pressure up to 50 kPa.

PTFE - Combines excellent resistance to the majority of chemicals with high mechanical strength and low weight. Frequently used in sulphate removal installations where other materials are easily damaged by toxic compounds. Suitable for installations with a constant working temperature up to +250°C and working pressure up to 50 kPa.

SI (Silicone) - Temperature resistance is similar to Viton. It maintains its mechanical properties in a very wide range of temperatures. Used in e.g. food industry as it is taste and odour free. Resistant to extreme weather conditions, but not resistant to acids, oils and abrasion. Suitable for dry and wet installations with a constant working temperature up to +200°C (temporarily even higher) and working pressure up to 20 kPa.

